

Trimform for profiled fibre cement sheeting



Choosing & using

**Profile 3
&
Profile 6**

TRIMFORM
Metal Fabrication Systems

Introduction

Why choose Marley Eternit fibre cement profile sheeting from Trimform

- Highly cost effective weatherproofing
- Virtually maintenance free
- No rust, rot or corrosion
- Resistant to chemical attack
- Vapour permeability reduces condensation
- Excellent noise and thermal insulation
- Quick and easy to install and fix
- Wide product and colour range
- 30 year guarantee (on request)
- Unbeatable after sales service

Contents

Introduction	1
Profile 6 and Profile 3	2
Windloadings	3
Accessories	4
Installation	5
Product selector	6
Ten easy steps to fixing	7
Working with fibre cement roofing sheets	8

Profile 6 and Profile 3

Trimform are distributors of Profile 6 and Profile 3 from Marley Eternit, the country's largest manufacturer of fibre cement products and the producers of profiled sheeting for over 90 years. The products are differentiated by the size of corrugation in the sheets; the Profile 3 having smaller corrugations than the Profile 6.

Both types of sheet are manufactured from a selected blend of Portland cement and water. This is reinforced with a mixture of both natural and synthetic fibres. The longevity of this formulation has enabled Marley Eternit to offer a 30 year guarantee on their sheets and fittings (available on request).

Marley Eternit have always worked to improve safety when using their range of roofing and cladding products. Building upon over 90 years experience in the UK roofing industry Marley Eternit have developed a purpose designed, reinforced fibre cement sheet - Profile 6 - that meets the high standards of safety in roofing work set out in the Health and Safety Executive document 'Health and Safety in Roof Work' (HSG 33). In addition to the Profile 6 sheet, Marley Eternit are proud to be able to offer a complementary range of accessories that meet the same high standards of safety.

Marley Eternit fibre cement profiled sheeting is manufactured in accordance with a quality system registered under BS EN ISO 9001. They also hold British Board of Agrément Certificate No. 00/3700.



Which profile?

The decision to use Profile 6 or Profile 3 sheets will depend largely upon the following four criteria:

- 1** The scale of the building in question.
- 2** Compatibility with any existing materials.
- 3** The distance from centre to centre of the horizontal fixing rails or purlins.
- 4** Whether or not the roofing material is to be classified as non-fragile.

Reference should therefore be made to the sheet sizes, fixing details and product data provided in this leaflet before deciding which type of profiled sheeting to use.

Profile 6

Profile 6 and safety in roof work

When correctly installed, Profile 6 has been tested and classified as non-fragile, and must be considered when working to the roof safety requirements of HSG 33. In addition, Profile 6 has also passed the French and Danish standards with flying colours.

Profile 6 is a high strength fibre cement sheet with polypropylene reinforcement strips inserted along precisely engineered locations which run for the full length of the sheet in each corrugation. This provides maximum reinforcement strength with no loss of durability in service.

Profile 6 sheet lengths (mm)

1525, 1675, 1825, 1975, 2125, 2275, 2440, 2600, 2750, 2900 & 3050.

Farmscape sheet lengths (mm)

1525, 1675, 2440, 2750 2900 & 3050.

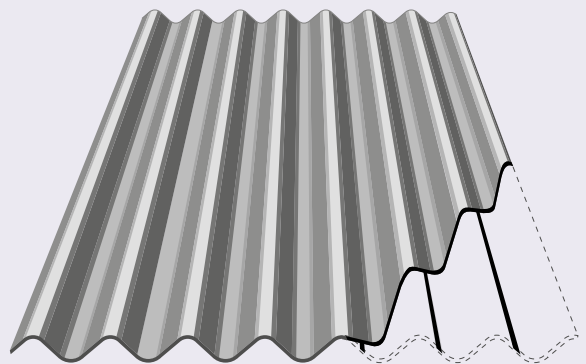

The cut-away illustration above shows the location of the polypropylene reinforcement strip inserted in a precisely engineered position in each corrugation of the Profile 6 sheet.

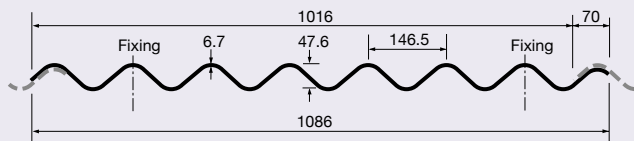

Other products

In order to ensure full compliance with HSG 33, ridges and rooflights must also be upgraded. Marley Eternit can supply a full range of accessories to ensure that the complete roof is non-fragile - see pages 4 to 6 for details.

Profile 3

The lower profile of this product makes it particularly suitable for a range of domestic, agricultural and light industrial buildings. It can be laid to a minimum roof pitch of 10°.

Profile 3 sheet lengths (mm)

1525, 2440 & 3050.

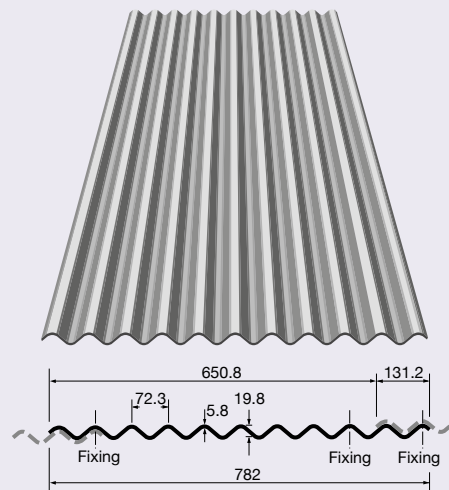

Technical data	Profile 6	Profile 3
Overall width	1086mm	782mm
Net covering width	1016mm	650.8mm
Thickness (nominal)	6.7mm	5.8mm
Density (nominal)	1450kg/m ³	1450kg/m ³
Pitch of corrugations (nominal)	146.5mm	72.3mm
Depth of profile	47.6mm	19.8mm
Profile height category	C	A
Side lap	70mm	131.2mm
Minimum end lap	150mm	150mm
Maximum purlin centres	1375mm	925mm
Maximum rail centres	1825mm	1525mm
Maximum unsupported overhang	350mm	250mm
Approx. weight of roof as laid, with 150mm end laps, single skin including fixings	17kg/m ²	14.5kg/m ²
Minimum roof pitch	5°	10°

Windloadings

When using profiled sheeting the windloadings of a location are critical to ensure the optimal sealing requirements.

Exposure zones

Approximate wind driven rain (litres/m² per spell)

- less than 56.5
- equal to or greater than 56.5



Notes

Map based on BS 5534: Part 1: 1997, Figure 1

When buildings stand above their surroundings or are situated in open country with no windbreaks within 1 km, they should be considered subject to severe exposure conditions.

Lap

This describes how much one sheet overlaps another at either the end (end lap) or the side (side lap).

Pitch

This describes the degree to which the roof slopes.

Guidance procedure

Step 1: Exposure

Determine the expected degree of exposure by examining the adjacent map.

Step 2: Centres of support

Support centres for roof sheeting should be a maximum of 1375mm for Profile 6, or 925mm for Profile 3, for a superimposed load of up to 1.89kN/m². There should be two fixings per sheet, per purlin. Where windloadings exceed this level, please contact the Marley Eternit Technical Department for advice before proceeding.

Step 3: Lap and seal

Establish requirement for lapping and sealing by reference to the exposure zones map of the UK and the table below. See page 5 for sealing details.

Step 4: Fixings

Sheltered and moderate sites

Less than 56.5 l/m ² wind driven rain per spell			
Minimum Roof pitch	End lap (mm)	Lap treatment End laps	Side laps
22.5° and over	150	Unsealed	Unsealed
15° and over	300	Unsealed	Unsealed
15° and over	150	Sealed	Unsealed
10° and over	150	Sealed	Sealed



Moderate and severe sites

More than 56.5 l/m ² wind driven rain per spell			
Minimum Roof pitch	End lap (mm)	Lap treatment End laps	Side laps
25° and over	150	Unsealed	Unsealed
17.5° and over	150	Sealed	Unsealed
15° and over	150	Sealed	Sealed
10° and over	300	Sealed	Sealed

Note

On roofs over 10° pitch where parapets might allow snow build up, 300mm double sealed end laps and single seal side laps are recommended. The minimum pitch for Profile 6 is 5°. Where slopes are between 5° and 10° the maximum slope length should be 15m with double sealed end laps and single sealed side laps.

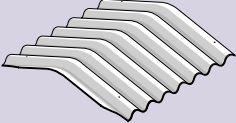
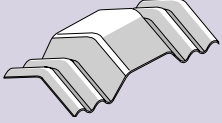
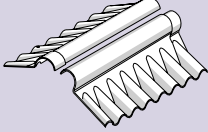
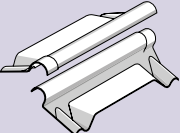
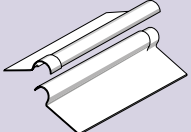
Accessories

	Profile 3	Profile 6
Cranked crown sheet 	N/A	Girth: 750 or 900mm Sizes: 5°, 7.5°, 10°, 12.5°, 15°, 17.5°, 20°, 22.5°
Ventilating crank crown 	N/A	Girth: 750mm Sizes: 5°, 7.5°, 10°, 12.5°, 15°, 17.5°, 20°, 22.5°
Two piece close fitting ridge 	Cover width: 650.8mm (adjustable)	Cover width: 1016mm (adjustable)
Two piece ventilating ridge 	Cover width: 650.8mm (adjustable)	Cover width: 1016mm (adjustable)
Two piece plain wing ridge 	Cover width: 650.8mm (adjustable)	Cover width: 1016mm (adjustable)
Hooded two piece ridge finial 	N/A	Available

Note
over widths indicated make allowance for overlap

	Profile 3	Profile 6
Eaves corrugation closure 	Cover width: 650.8mm Size: 75mm (effective leg length) Handed left & right	Cover width: 1016mm Sizes: Size: 65, 100, 150, 250mm (effective leg length) Universal
Eaves filler 	Cover width: 650.8mm Handed left & right	Cover width: 1016mm Universal
Apron flashing 	Cover width: 650.8mm Size: 120° Handed right	Cover width: 1016mm Size: 124° Handed left
Roll top barge board 	Cover widths (200mm wing): 1800mm (1650mm cover) 2440mm (2250mm cover) 3000mm (2850mm cover) Farmscape: 1525, 2440mm	
External corner 	Cover widths (200mm wing): 1800mm (1650mm cover) 2440mm (2250mm cover) Cover width (300mm wing): 3000mm (2850mm cover)	

Installation

Whilst Marley Eternit profiled sheeting is easy to install, the following guidelines should be observed:

- The sheets should be installed smooth surface up.
- The sheets should be cut with a hand saw or slow speed reciprocating power saw.
- All fixing holes should be drilled, not punched, and should provide adequate clearance for the fastener shank (minimum 2mm).
- There should be two fixings per purlin or rail covered at the fixing points shown on page 2.
- When using power tools in a confined area, dust extraction equipment is advisable.
- The dust and swarf generated when working with the sheets does not require any special handling requirements other than normal good housekeeping to maintain a clean working area.

Fixing

The correct fixing of a sheet is important in order to avoid premature failure, corrosion or leaks in a roof. Many factors influence the fixing of a roof, such as the purlin or rail type and the nature of the roof in question. Particularly important is the type of fastening system used and compliance with the manufacturer's recommendations.

When fixing Profile 6 fibre cement profiled sheeting on roof slopes up to 30° (double skin up to 15°) we recommend the use of topfix fasteners from SFS Stadler Limited. These fasteners provide a quick and effective one step fixing operation. However, they must be installed using the recommended depth locating power tool to prevent under or over tightening, which can damage the roof sheets.

When topfix fasteners are not used, the recommended fastener diameter is 8mm, which requires a clearance hole of 8mm + 2mm = 10mm. If using drive screws, the holes should be located centrally on the timber purlins; for hook bolts or similar the hole should be located 4mm upslope from the back edge of the purlin. 6mm diameter fasteners can be used for Profile 3.

Note

In all instances the Sela washers and protective caps manufactured by SFS Stadler Ltd should be utilised to ensure adequate weather protection.

Checking the topfix fasteners for tightness

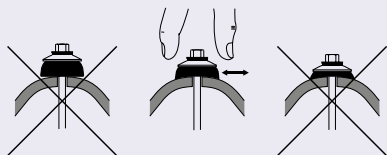

Overhangs

Sufficient overhangs must be allowed at the eaves to ensure that rainwater discharges into the gutter. Verges must be overhung by one complete corrugation unless a bargeboard is used.

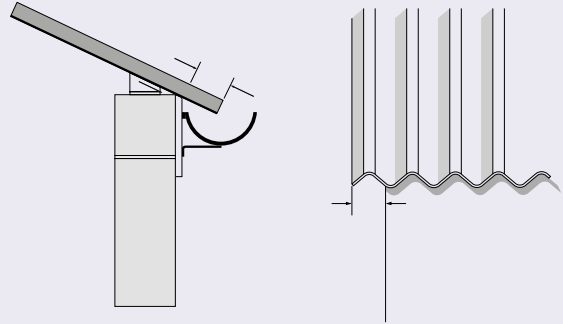

Side Laps

Sealing

Where appropriate, 8mm diameter butyl strips should be positioned as shown.

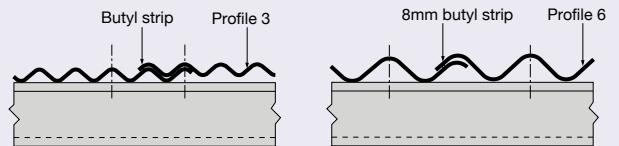

End Laps

The minimum end lap for either Profile 3 or Profile 6 is 150mm, fixed as shown in the section below.

Where double sealing is necessary, the second butyl strip should be positioned 100-200mm below the fixing.

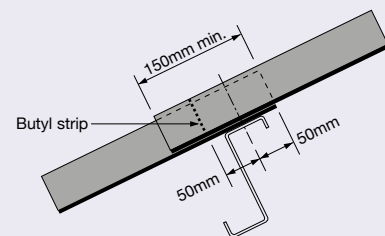

Product Selector

1 Two-piece plain wing ridge cover

Adjustable over range of roof pitches.

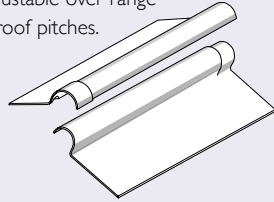

2 Cranked crown sheet

For covering apex of roof.

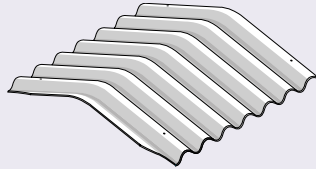

9 Hooded two piece ridge finial

Made to suit roll top bargeboards with two-piece adjustable ridge only. Profile 6R only

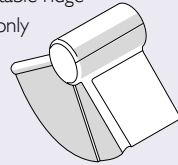

3 Ventilating cranked crown

For ventilation at apex of roof.

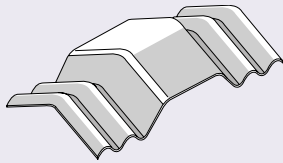

4 Apron flashing

For weathering top of mono-pitch lean-to roofs.

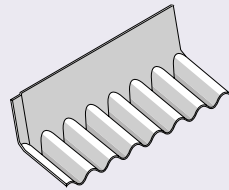

10 Two piece ventilating ridge cover

Adjustable over range of roof pitches providing natural ventilation

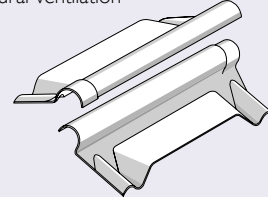

5 Roll top bargeboard

Decorative trim for corner junction of roof and gable end wall.

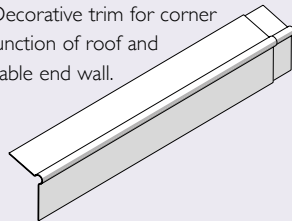

6 External corner

Plain wing cover trim for wall-to-wall and roof to gable end wall.

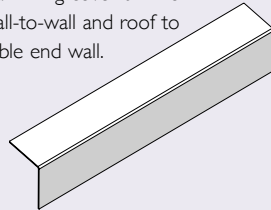

11 Two piece close fitting ridge cover

With profile wings adjustable over range of roof pitches



7 Eaves corrugation closer

For blanking off corrugation voids at eaves of roof.

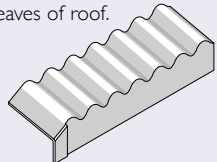

8 Eaves filler

For blocking corrugation voids at eaves of roof

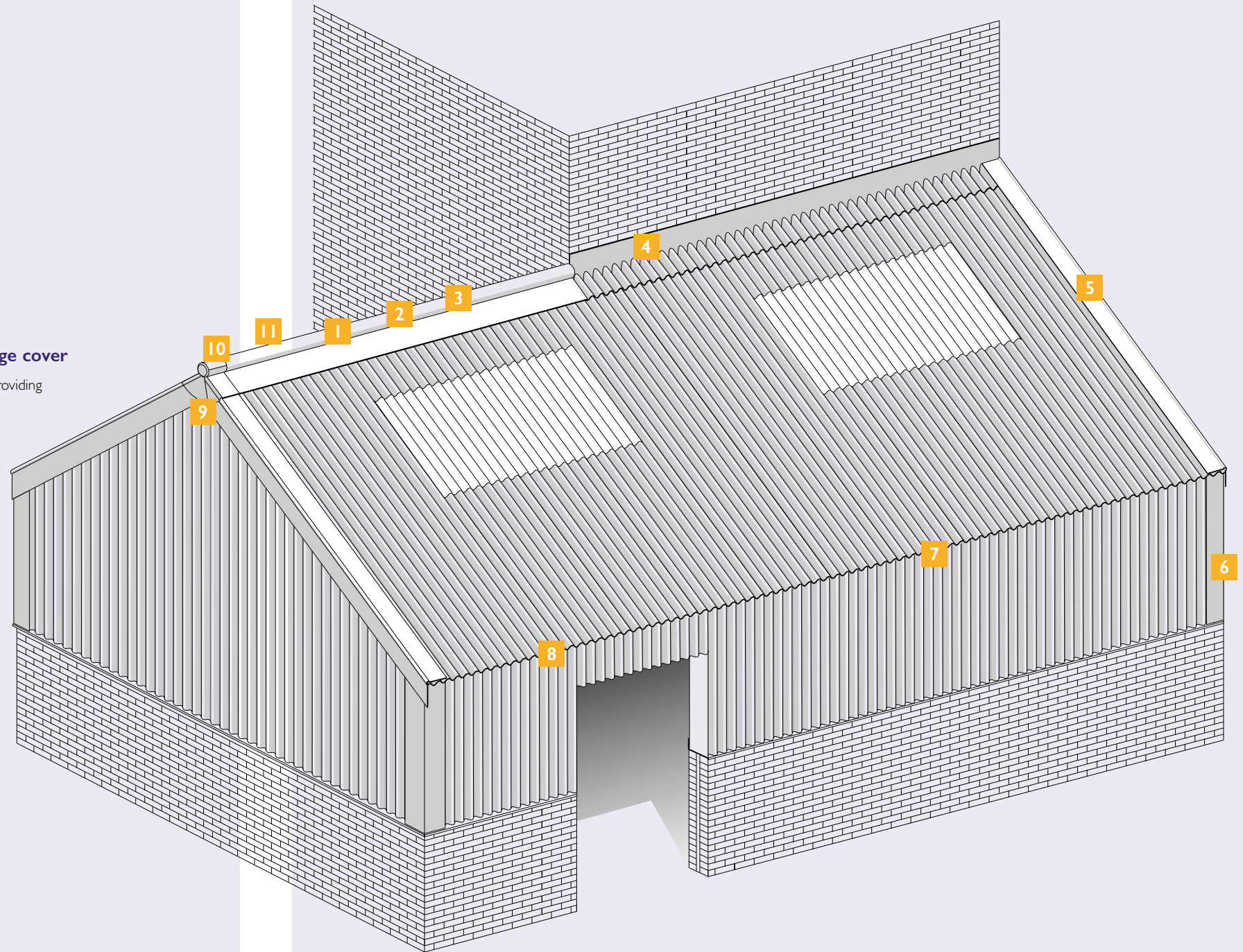
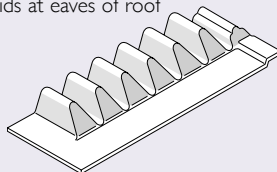

Ten easy steps to fixing

The fixing of a fibre cement roof can be accomplished by most people if they follow these ten easy steps in conjunction with the illustrations opposite. In order to weatherproof the roof, the butyl strip must be installed as described on page 5, and mitres cut to avoid having four thicknesses of sheeting in the same plane at the junctions of sides and end laps.

- 1 Lay sheet number 1 at the eaves without mitring.
- 2 Lay sheet number 2, mitring bottom right hand corner as per the illustration opposite.
- 3 Lay sheet number 3, mitring as per step 2. Continue up the roof slope to complete the first tier.
- 4 Lay sheet number 4 at the eaves of the next tier, mitring the top left hand corner as per the illustration opposite.
- 5 Lay sheet number 5, mitring both top left hand and bottom right hand corners as per illustration opposite, and continue up the slope until ready to lay sheet number 6 at the ridge.
- 6 Lay sheet number 6 at the ridge, mitred as per step 2.
- 7 Repeat the procedure from and including step 4, working across the roof from eaves to ridge, until there is room for only one more tier to be laid, on the right hand edge.
- 8 Lay sheet number 7, mitring the top left hand corner. If necessary, reducing the sheet width by cutting down the right hand edge. All subsequent sheets in this final tier should be cut accordingly.
- 9 Lay sheet number 8 as per step 7, continuing up the roof slope until ready to lay the final sheet at the ridge.
- 10 Lay sheet number 9 at the ridge without mitring to complete the roof.

Notes

- 1 On a duo pitch roof start both slopes from the same end of the building. One slope will therefore be sheathed left to right, the opposite slope will be sheathed right to left.
- 2 The corrugations of sheets must line up at the apex to ensure that the ridge accessories will fit.
- 3 When cranked crown sheets are used, both top courses of roofing sheets and the cranked crowns themselves must be mitred.
- 4 Always lay sheets with the correct end and side laps, as detailed elsewhere in this booklet.
- 5 Do not cut mitres in situ.

Mitring plan single slope roof

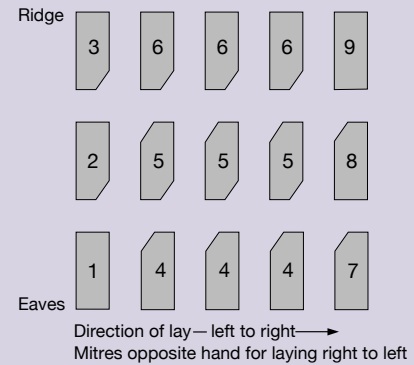

Mitring Profile 3

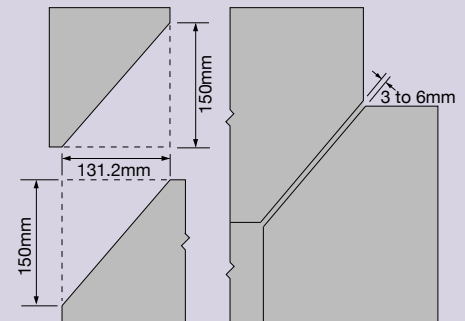

Mitring Profile 6

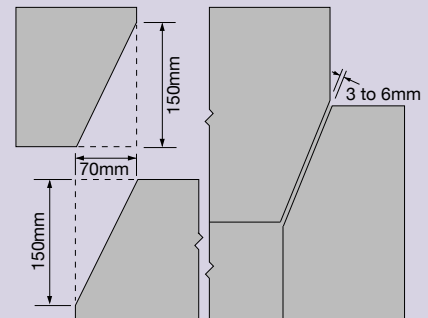

Working with Marley Eternit fibre cement roofing

Storage and handling

- When handling sheets, lift by the ends only.
- Stack sheets on firm, level ground to a maximum height of 1 m. If on bearers, use at least 2 bearers for sheets up to 1.5m long and at least 3 bearers for longer sheets.
- Protect from damage. Store as close as possible to fixing site, allowing room for handling.
- Stack smooth face up.
- Protect from wind by stacking in a sheltered position or by holding down top sheets with ropes, weights or clips.
- A separate stack should be made of each length of sheet. If this is not possible, stack with the smallest on top and the longest at the bottom.
- If the sheets have been delivered in shrink-wrapped polythene, this should be retained for as long as possible. Partially used stacks should be protected from the weather by extending the top sheets 200mm at each end.
- After installation please note that due to the vapour permeability of Marley Eternit fibre cement profile sheeting, dampness may appear on the underside of the sheet. This is a well known temporary phenomenon and will disappear following successive wet and dry periods. It in no way affects the weatherproof quality of the sheets.

Safety

- The structure should be adequately prepared for the sheets.
- The position and fixing of all purlins and rails should be checked before starting sheeting.
- Ensure there is proper access to the roof.
- Workmen should not work directly beneath the area being sheeted.
- Provide a scraper at the bottom of all ladders to remove mud from boots.
- Sheeters should wear suitable clothing: wear boots or shoes (not Wellington boots), avoid loose, flapping clothing, avoid trousers with turn-ups.
- Treat as a fragile roof and always use crawling boards, roof ladders or walkways.
- Workmen should not be allowed to use the roof as a working platform during sheeting.
- Materials should not be stacked on the roof.
- It is possible for one man to safely handle smaller sheets at roof level on a calm day. However, safe handling of profiled sheets on a roof may require two men in certain circumstances.
- Two men are always required to lay the eaves course and the sheets above rooflights.
- Always lay the sheets in accordance with the approved sequence.
- Do not cut the sheets in a confined space since nuisance dust will be created.
- Remove all loose material from the roof as the work proceeds.
- Always fully fix the sheets as the work proceeds.
- Do not leave tools on the roof surface.
- Avoid deflecting a sheet whilst attempting to force a bearing.
- Sheets should be laid in tiers from the eaves to the ridge, thereby allowing easier use of crawling boards.
- Correct staging should always be laid over the purlins ahead of the sheeting.
- Where regular access is required to reach roof lights, ventilation and service ducts, properly constructed walkways should be provided.
- Take extra care on a roof during windy, wet or frosty weather.
- Take extra care on painted sheets whose surface will be more slippery than natural grey sheets.
- Do not step on side lap corrugations.

In addition to the Construction (Design and Management) Regulations 1994 (CDM), always observe the relevant provisions of the Health and Safety at Work legislation currently in force.

TRIMFORM

Metal Fabrication Systems

If you'd like to know more about any of our products or services, contact us using the details below.

One of our team will be happy to help in any way.

Tel: **01480 461103** Fax: **01480 461102** Email: info@trimformfabs.co.uk

Trimform Products

(A trading division go SIG Trading Limited) Harding Way, Somersham Road, St. Ives, Huntingdon, Cambridgeshire, PE27 3WR.