

TECHFIX™*

• Fixings • Fasteners • Stainless • Ruspert Coated Fasteners • Colour Moulded Head Range • Tapes • Sealants •



WOODALL FS
FASTENING SYSTEMS

TECH
FASTENERS



ONE GROUP

WOODALL FS • WOODALL BS • TECH FASTENERS • SCHREIBER • VANGUARD FIXINGS • SUPERSPARES



CONTENTS...

Stainless Steel Screws	1
Stainless Steel Screws In TechColour Moulded Head	2
Stainless Steel Screws for Composite Panel to Purlins 1.2mm to 3.6mm	3
Stainless Steel Screws for Composite Panel to Purlins 6.0mm to 12.5mm	4
Bi-Metal A2 Stainless Steel Screws & Halter Fixings	5
A2 Stainless Steel Self Tapping Screws	6
Organic Coated Screws	7
Organic Coated Screws in TechColour Moulded Head	8
Organic Coated Screws for Composite Panel to Purlins 1.2 - 3.6mm thick	9
Installation Recommendations & Technical Appendix	10
Techfix for Light Section Purlins 1.2mm to 3.6mm	11
Techfix for Heavy Section Purlins 6.0mm to 12.5mm	12
Stitching Fasteners	13-14
Techfix for Sheet to Timber	14
Techfix for Liner Trays & Panels	15-16
High Threads for Composite Panel Sheeting to Light Purlins: 1.2 to 3.6mm and to Timber	17
High Threads for Composite Panel Sheeting to Heavy Purlins: 6.0 to 12.5mm	18
Wing Drillers for Timber to Steel	19
Fibre Cement Screws	19
Self Tapping Screws	20
Screws - General Applications	21
Washers	22
Colour Matched Moulded Head Fixings	23
Colour Matched Moulded Head Fixings for Composite Panel	24
Low Profile Fixings	25-26
Pan Head Decking Screws	27-28
Application Guide for Metal Framing System	29
25 / 15 Frame Fix Channel	30
Colour Codes for Caps & Moulded Head Screws	31
Insulation Hangers	32
Tapes, Sealants & Silicones	33-34
Foam Fillers	35
Pipe Flashings	36
Power Tools	37
Accessories	38
Also Available From WFS	39-40



Stainless Steel Screws

Our range of bi-metallic fixings are available in 304 / A2 grade austenitic stainless steel to meet the demands of a variety of cladding applications. Single skin profiled metal, composite panel and other insulation buildups can all be fixed to light and heavy section steel.

An insurance backed warranty is the quality assurance that puts our bi-metallic fixings in a position to be used in conjunction with the industry's leading sheet and panel suppliers. Speak to a member of our sales team today for further details.

FOR PURLINS 1.5 - 3.6MM...

Order Code	BML25S16	BML32S16	BML45S16	BML57S16
Size	5.5 x 25mm	5.5 x 32mm	5.5 x 45mm	5.5 x 57mm
ESL	10mm	16mm	21mm	29mm

FOR PURLINS 6.0 - 12.5MM...

Order Code	BMH40S16
Size	5.5 x 40mm
ESL	12mm

Order Code	BMS27S16
Size	6.3 x 27mm
ESL	2 sheets x 1.25mm

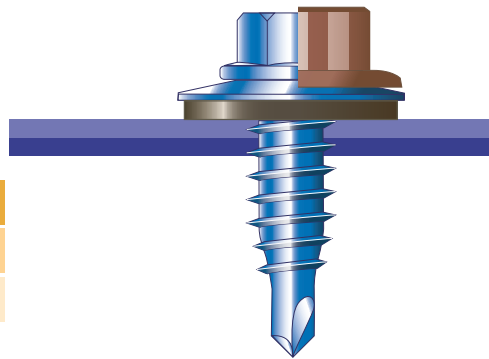

HEXAGON HEAD COLOUR CAPS		
Order Code	HC3/HC5	HC6
To Suit	16mm and 19mm Washers	29mm Washer
Product		

Available in B.S. and RAL colours

SCREW AND WASHER CODING	
BML25	SB16
Screw Code	Washer Code
For unwashed simply use NW	
For 16mm washer simply use SB16	
For 29mm washer simply use SB29	

TECHSEAL STAINLESS STEEL WASHER			
Order Code	SB16	SB19	SB29
Product			

For Dekfast washers see page 22

TIMBER SCREWS...

Order Code	SS40S16
Size	6.3 x 40mm
ETL	35mm

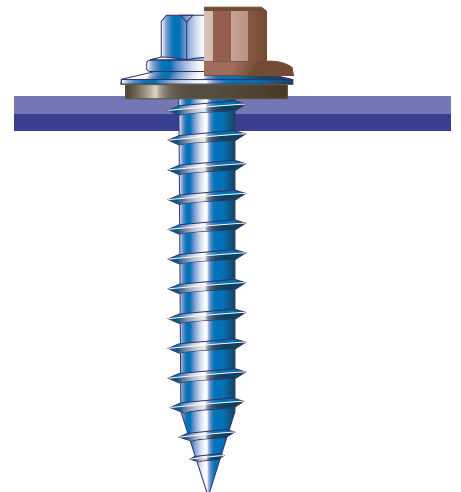

Stainless Steel Screws

in TECHCOLOUR™ Moulded Head

Order Code	BML25S16-MH	BML32S16-MH	BML45S16-MH	BML57S16-MH
Size	5.5 x 25mm	5.5 x 32mm	5.5 x 45mm	5.5 x 57mm
ESL	10mm	16mm	21mm	29mm

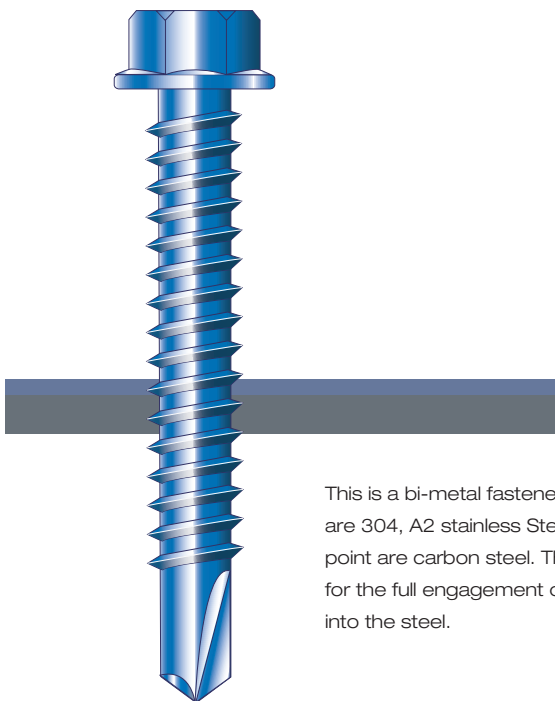

This is a bi-metal fastener. The head and majority of thread are 304, A2 stainless Steel. The final few threads and drill point are carbon steel. The Effective Stainless Length allows for the full engagement of the Stainless portion of the screw into the steel.

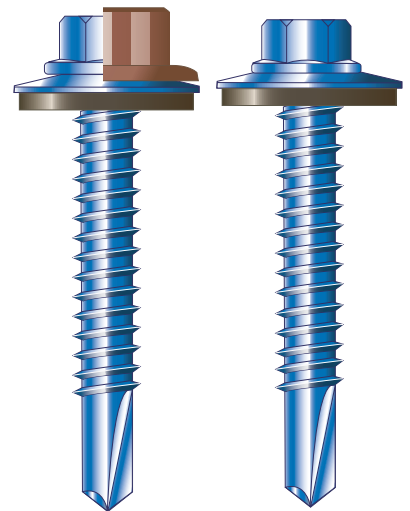

SCREW AND WASHER CODING	
BML25	SB16
Screw Code	Washer Code
For unwashed simply use NW	
For 16mm washer simply use SB16	
For 29mm washer simply use SB29	

TECHSEAL STAINLESS STEEL WASHER			
Order Code	SB16	SB19	SB29
Product			

For Dekfast washers see page 22



Stainless Steel Screws for Composite Panel to Purlins 1.2mm to 3.6mm

Order Code	BMCL85S16	BMCL110S16	BMCL130S16	BMCL165S16
Size	5.5 x 85mm	5.5 x 110mm	5.5 x 130mm	5.5 x 165mm
ESL	70mm	95mm	114mm	149mm
Ins. Thickness	35-60mm	55-85mm	60-100mm	110-145mm



All stainless steel fixings for composite panel are available in Techcolour moulded head

For Moulded Headed Screws just add colour code on page 31 to the screw codes above.
(eg MH53 for Moulded Head Goosewing Grey)

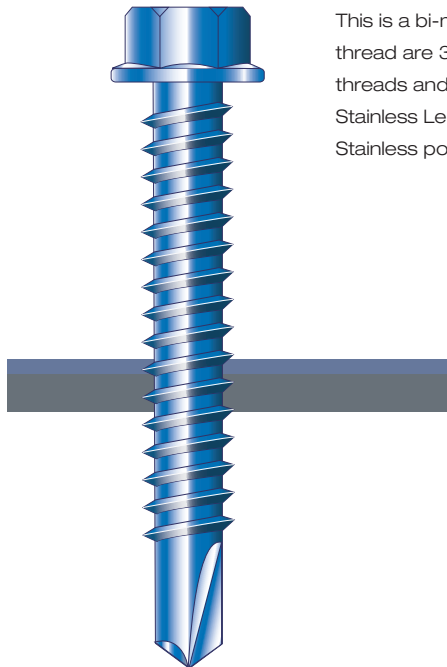

This is a bi-metal fastener. The head and majority of thread are 304, A2 stainless Steel. The final few threads and drill point are carbon steel. The Effective Stainless Length allows for the full engagement of the Stainless portion of the screw into the steel.

HEXAGON HEAD COLOUR CAPS		
Order Code	HC3/HC5	HC6
To Suit	16mm and 19mm Washers	29m Washer
Product		

Available in B.S. and RAL colours

SCREW AND WASHER CODING	
BMCL85	SB16
Screw Code	Washer Code
For unwashed simply use NW	
For 16mm washer simply use SB16	
For 29mm washer simply use SB29	

TECHSEAL STAINLESS STEEL WASHER			
Order Code	SB16	SB19	SB29
Product			

For Dekfast washers see page 22

Stainless Steel Screws for Composite Panel to Purlins 6.0mm to 12.5mm

Order Code	BMCH85S16	BMCH110S16	BMCH130S16
Size	5.5 x 85mm	5.5 x 110mm	5.5 x 130mm
ESL	60mm	85mm	105mm
Ins. Thickness	40-50mm	50-70mm	70-90mm

All stainless steel fixings for composite panel are available in Techcolour moulded head

For Moulded Headed Screws just add colour code on page 31 to the screw codes above.

(eg MH53 for Moulded Head Goosewing Grey)

This is a bi-metal fastener. The head and majority of thread are 304, A2 stainless Steel. The final few threads and drill point are carbon steel. The Effective Stainless Length allows for the full engagement of the Stainless portion of the screw into the steel.

HEXAGON HEAD COLOUR CAPS		
Order Code	HC3/HC5	HC6
To Suit	16mm and 19mm Washers	29m Washer
Product		

Available in B.S. and RAL colours

SCREW AND WASHER CODING	
BMCL85	SB16
Screw Code	Washer Code
For unwashed simply use NW	
For 16mm washer simply use SB16	
For 29mm washer simply use SB29	

TECHSEAL STAINLESS STEEL WASHER			
Order Code	SB16	SB19	SB29
Product			

For Dekfast washers see page 22

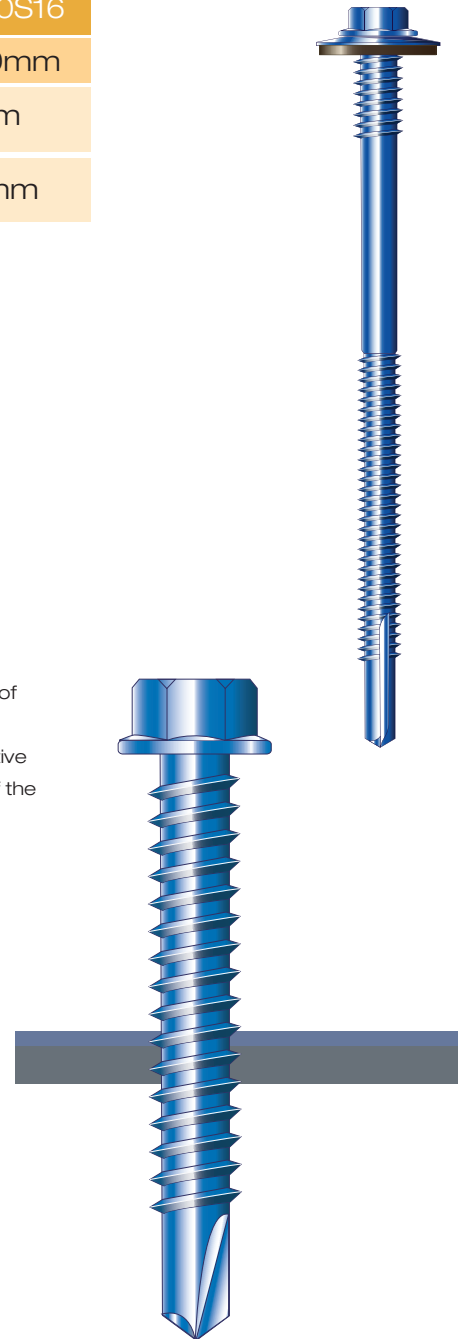

Bi-Metal A2 Stainless Steel Screws & Halter Fixings

Order Code	BMHF38S16	BMHF47S16
ESL	20mm	29mm
Application	Halter & Pad to 1.25 - 3.5mm Purlin	Halter & Pad to 1.5 - 6.0mm Purlin

Order Code	SS40S16	10W
ESL	N/A	N/A
Application	Halter & Pad to timber	Halter & Pad to decking

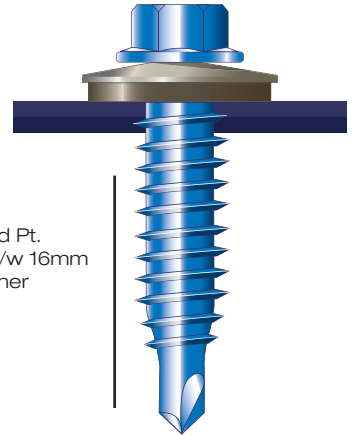

6.3 x 38mm
No. 2 Reduced Pt.
Halter Fixing c/w 16mm
Techseal Washer

HEXAGON HEAD BI-METAL SCREWS FOR PURLINS 1.2 - 3.5MM

Order Code	Size	ETL	Max Steel Thick
BM75404219	4.2 x 19	9.5mm	3.5mm
BM75404224	4.2 x 24	14.5mm	3.5mm
BM75404822	4.8 x 22	10.5mm	4.5mm
BM75404824	4.8 x 25	13mm	4.5mm
BM75404830	4.8 x 31	19mm	4.5mm

A2 Stainless Steel Self Tapping Screws

STAINLESS STEEL

AB POINT FOR STAINLESS STEEL THICKNESS UP TO 3MM

Order Code	SCF
SS25	25mm
SS30	30mm
SS40	40mm
SS50	50mm
SS65	65mm
SS75	75mm
SS90	90mm
SS100	100mm
SS120	120mm

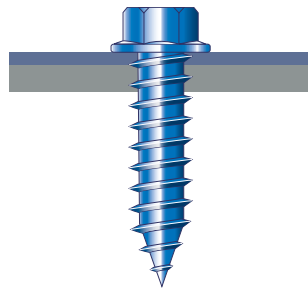

Material Thickness	Screw Type	Screw Diam
0.7 - 0.85mm	AB	3.95mm
0.8 - 1.25mm	AB	4.75mm
1.25 - 1.90mm	AB	5.05mm
1.90 - 3.0mm	AB	5.10mm

B POINT FOR STAINLESS STEEL THICKNESS UP TO 3MM

Order Code	SCF
STS25B	25mm
STS32B	32mm
STS38B	38mm
STS50B	50mm
STS65B	65mm
STS75B	75mm
STS90B	90mm
STS100B	100mm
STS125B	125mm

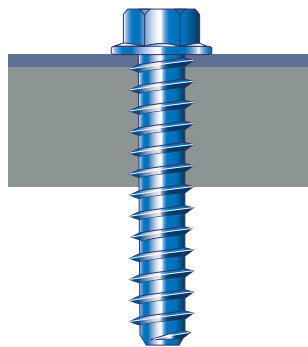

Material Thickness	Screw Type	Screw Diam
2.7 - 3.45mm	B	5.3mm
3.45 - 4.75mm	B	5.6mm
4.75 - 7.95mm	B	5.8mm
over 7.95	B	5.95mm approx

Organic Coated Screws

Woodall Fastening Systems are proud to offer our TechSeal 1000 range of fixings. A rustproof organically coated fastener offering an increased fixing lifespan and a greater resistance to corrosion than a zinc plated carbon steel part. At a more economic price than a bi-metallic stainless steel fixing, the TechSeal 1000 range is an excellent choice for your next project. TechSeal 1000 is available in all washed and unwashed variants and in our RAL and BS colour matched TechColour integral moulded head. Speak to our sales team today for a quick and competitive price.

Order Code	DLS25SA16	DLS45A16	DLS57A16	DLS70A16	DLS100A16
Size	5.5 x 25mm	5.5 x 45mm	5.5 x 57mm	5.5 x 70mm	5.5 x 100mm
Purlin Thickness	1.2 to 3.6mm				
ETL	9mm	28mm	44mm	54mm	82mm

Order Code	DHS40A16	DHS60A16	DHS80A16
Size	5.5 x 40mm	5.5 x 60mm	5.5 x 80mm
Purlin Thickness	6.0 to 12.5mm		
ETL	19mm	37mm	55mm

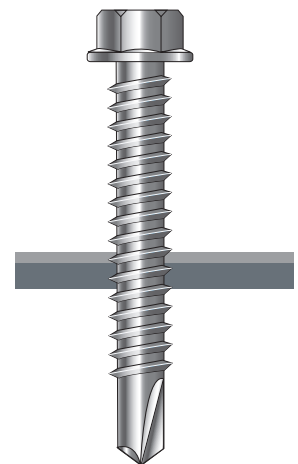

HEXAGON HEAD COLOUR CAPS		
Order Code	HC3/HC5	HC6
To Suit	16mm and 19mm Washers	29mm Washer
Product		

Available in B.S. and RAL colours

SCREW AND WASHER CODING	
DLS25	A16
Screw Code	Washer Code
For unwashed simply use NW	
For 16mm washer simply use A16	
For 29mm washer simply use A29	

TECHSEAL ALUMINIUM WASHER			
Order Code	A16	A19	A29
Product			

For Dekfast washers see page 22

Organic Coated Screws

in TECHCOLOUR™ Moulded Head

Order Code	DLS25SA16-MH	DLS45A16-MH	DLS57A16-MH	DLS70A16-MH	DLS100A16-MH
Size	5.5 x 25mm	5.5 x 45mm	5.5 x 57mm	5.5 x 70mm	5.5 x 100mm
Purlin Thickness	1.2 to 3.6mm				
ETL	9mm	28mm	44mm	54mm	82mm

Order Code	DHS40A16-MH	DHS60A16-MH	DHS80A16-MH
Size	5.5 x 40mm	5.5 x 60mm	5.5 x 80mm
Purlin Thickness	6.0 to 12.5mm		
ETL	19mm	37mm	55mm

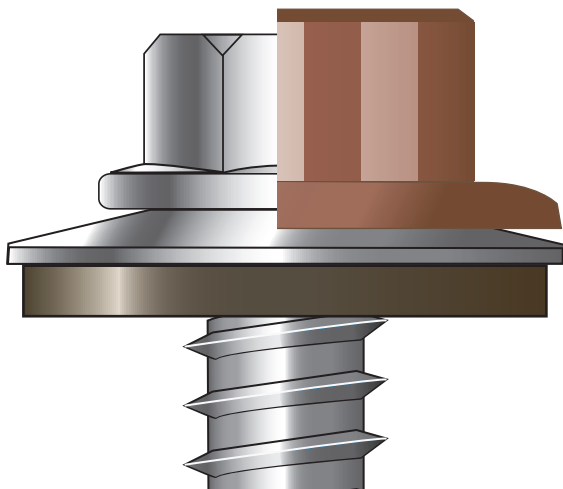
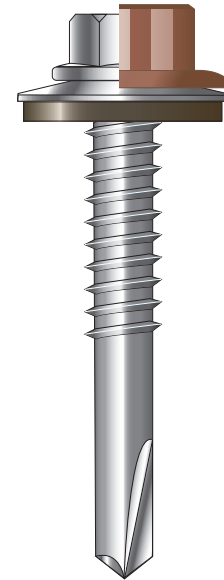

SCREW AND WASHER CODING	
DLS25	A16
Screw Code	Washer Code
For unwashed simply use NW	
For 16mm washer simply use A16	
For 29mm washer simply use A29	

TECHSEAL ALUMINIUM WASHER			
Order Code	A16	A19	A29
Product			

For Dekfast washers see page 22



Organic Coated Screws for Composite Panel

FOR PURLINS 1.2 - 3.6MM...

Order Code	DCPLS65A19	DCPLS75A19	DCPLS85A19	DCPLS115A19
Size	5.5 x 65mm	5.5 x 75mm	5.5 x 85mm	5.5 x 115mm
ETL	45mm	57mm	70mm	97mm
Ins. Thickness	30-40mm	30-50mm	40-65mm	55-90mm

Order Code	DCPLS135A19	DCPLS150A19	DCPLS165A19
Size	5.5 x 135mm	5.5 x 150mm	5.5 x 165mm
ETL	119mm	135mm	145mm
Ins. Thickness	60-110mm	75-125mm	100-140mm



FOR PURLINS 6.0 - 12.5MM...

Order Code	DCPHS75A19	DCPHS85A19	DCPHS105A19
Size	5.5 x 75mm	5.5 x 85mm	5.5 x 105mm
ETL	52mm	62mm	82mm
Ins. Thickness	40-45mm	35-50mm	55-70mm

Order Code	DCPHS125A19	DCPHS135A19	DCPHS150A19
Size	5.5 x 125mm	5.5 x 135mm	5.5 x 150mm
ETL	102mm	112mm	127mm
Ins. Thickness	50-90mm	65-100mm	75-115mm



All Techseal fixings for composite panel are available in Techcolour moulded head

For Moulded Headed Screws just add colour code on page 31 to the screw codes above.

(eg MH53 for Moulded Head Goosewing Grey)

Installation Recommendations & Technical Information

Techfix Self Drilling Screws are designed and manufactured to work first time - every time. Whilst the product is able to withstand a certain amount of misuse, optimum results can be obtained by adhering to a few simple guidelines.

Fastener Selection

Always use the correct screw for the application - ensuring that total material build up and thickness are within the stated capacity of the screw. Please telephone our technical support department if in doubt.

Correct Power Tool for Driving

For proper installation of all techfix drill screws a suitable electric screw gun and magnetic drive socket must always be used. The screw gun should incorporate both clutch and depth location mechanisms. The adjustable nose-piece should always be used to ensure correct driving of screws and compression of washers.

RECOMMENDED DRILL SPEED

Screw Diameter	Minimum	Maximum
up to 4.8mm	1800	2200
up to 5.5mm	1000	1600
up to 6.3mm	1000	1600

PULL-OUT VALUE (kN)

Screw Gauge & Pt Type	Steel Thickness (mm)									
	0.7	2 x 0.7	1.6	2.0	2.5	2.8	3.2	4.0	5.0	6.0
5.5 dia -No.2pt	-	-	4.1	5.1	7.4	9.6	10.7	-	-	-
5.5 dia -No.3 pt	-	-	3.9	4.8	7	8	9.7	12.3	-	-
5.5 dia -No.5 pt	-	-	-	-	-	-	-	11.6	14.1	14.1
6.3 dia -No.3 pt	-	-	4.1	5.3	7.6	8.3	9.9	11	-	-
6.3 dia -No.1 pt	1.5	3	-	-	-	-	-	-	-	-

Adjustments and Use of Power Tools

It is important that site operatives/installers take sufficient care and time making proper adjustments to power tools (screws and guns etc) in order to ensure that washer compression is correct.

SHEAR STRENGTH

Screw Gauge	KN
No. 6 - 3.5mm	2.9
No. 8 - 4.2mm	4.4
No. 10 - 4.8mm	6.3
No. 12 - 5.5mm	8.4
No. 14 - 6.3mm	12.3

TENSILE STRENGTH

Screw Gauge	KN
No. 6 - 3.5mm	5
No. 8 - 4.2mm	7
No. 10 - 4.8mm	10
No. 12 - 5.5mm	14.1
No. 14 - 6.3mm	17



TECHFIX™ Light... for Purlins 1.2mm to 3.6mm

For fixing profiled sheet metal to light section / cold rolled steel purlins. A comprehensive fixing range offering ease of installation and a secure fix.

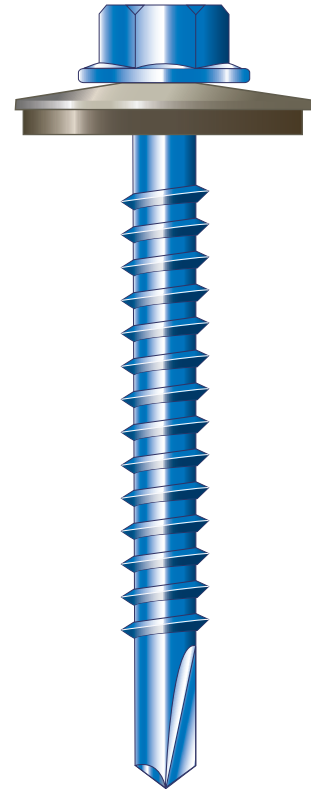

Order Code	T14GB16	T15GB16	T11GB16	T12GB16
Size	5.5 x 25mm	5.5 x 32mm	5.5 x 38mm	5.5 x 43mm
ETL	9mm	14mm	15mm	30mm

Order Code	T21GB16	T23GB16	T38GB16
Size	5.5 x 51mm	5.5 x 57mm	5.5 x 70mm
ETL	36mm	43mm	62mm



Order Code	GB16	GB19	GB29
Product			

For Dekfast washers see page ??

Order Code	HC3 / HC5	HC6
To Suit	16mm / 19mm Washer	29mm Washer
Product		

Available in B.S and RAL colours see page 31

SCREW AND WASHER CODING	
T14	GB16
Screw Code	Washer Code
For unwashed simply use NW	
For 16mm washer simply use GB16	
For 29mm washer simply use GB29	

TECHFIX™ Heavy...



for Purlins 6.0mm to 12.5mm

For fixing profiled sheet metal to heavy section / hot rolled steel purlins. A comprehensive fixing range offering ease of installation and a secure fix.

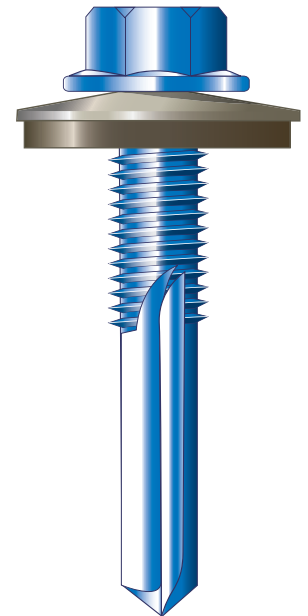

Order Code	T32GB16	T47GB16	T24GB16	T26GB16
Size	5.5 x 25mm	5.5 x 32mm	5.5 x 38mm	5.5 x 50mm
ETL	7mm	11mm	17mm	30mm

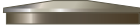
Order Code	T27GB16	T33GB16	NTL100GB16
Size	5.5 x 60mm	5.5 x 80mm	5.5 x 100mm
ETL	40mm	55mm	79mm



Order Code	GB16	GB19	GB29
Product			

For Dekfast washers see page ??

Order Code	HC3 / HC5	HC6
To Suit	16mm / 19mm Washer	29mm Washer
Product		

Available in B.S and RAL colours see page 31

SCREW AND WASHER CODING	
T32	GB16
Screw Code	Washer Code
For unwashed simply use NW	
For 16mm washer simply use GB16	
For 29mm washer simply use GB29	



STITCHING SCREWS...

Order Code	T1420GB16
Max Thickness	3 Sheets x 0.7mm

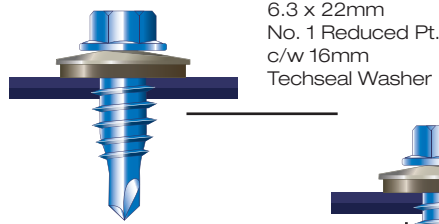

Order Code	T1427GB16	T1625GB19
Max Thickness	3 Sheets x 0.7mm	3 Sheets x 0.7mm

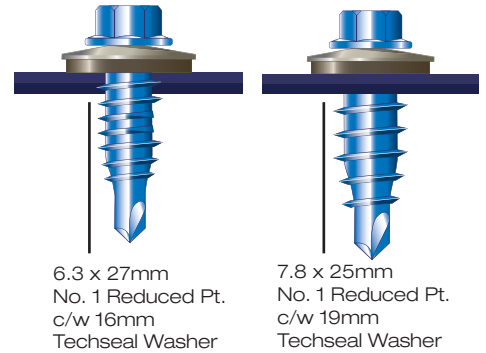

STANDARD RIVETS...

Order Code	AD68 (AL4811)	1661/0619 (AL4818)	SD68SB	RC3-Colour
Size	4.8 x 11.5mm	4.8 x 18mm	4.8 x 12mm	
Material	Aluminium	Aluminium	Steel	Steel
Cap to Suit	RC3	RC3	RC3	Available in
Grip Range	0.5mm to 6.4mm	0.9mm to 14.0mm	0.5mm to 6.4mm	B.S and RAL Colours
Drill Bit	4.9mm	4.9mm	4.9mm	



BULBTITE RIVETS...

Order Code	3W	4W	6W
Size	5.2 x 17.5mm	5.2 x 19.1mm	5.2 x 22.2mm
Material	Aluminium	Aluminium	Aluminium
Cap to Suit	RC1	RC1	RC1
Grip Range	0.5mm to 4.75mm	1.5mm to 6.35mm	4.75mm to 9.5mm
Drill Bit	5.3mm	5.3mm	5.3mm



Order Code	8W	10W	RC1-COLOUR
Size	5.2 x 25.4mm	5.2 x 28.6mm	
Material	Aluminium	Aluminium	Rivet Cap
Cap to Suit	RC1	RC1	Available in
Grip Range	7.9mm to 12.7mm	11.6mm to 15.8mm	B.S and RAL Colours
Drill Bit	5.3mm	5.3mm	



TECHFIX™ Stitching Fasteners

ROOFLIGHT STITCHING SCREWS...

Order Code	25LGB	38LGB
Maximum Grip Range	16mm	25mm
Recommended Drill Size	10.0mm	10.0mm

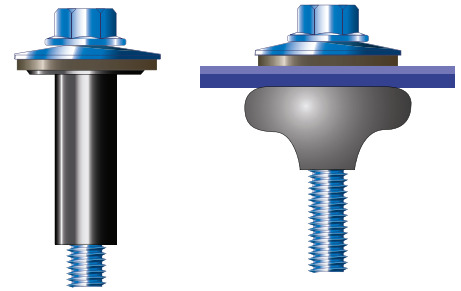

25mm Plug c/w 19mm Galvanised Bonded Washer and Hex Screw
Also available with Poppy Red TechColour Nylon Head

ROOFLIGHT STITCHING SCREWS...

Order Code	38LAP
Maximum Grip Range	25mm
Recommended Drill Size	10.0mm

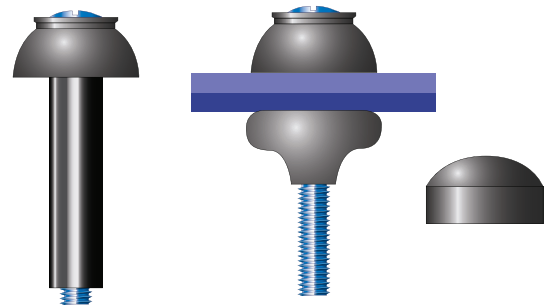

38mm Plug c/w Black 20mm Sela Washer and Roofing Bolt Head

TECHFIX™ Sheet to Timber

TYPE 17 'S' POINT TIMBER SCREWS...

Order Code	T16GB16	T39GB16	T28GB16
Size	6.3 x 25mm	6.3 x 32mm	6.3 x 45mm
Penetration	20mm	27mm	40mm

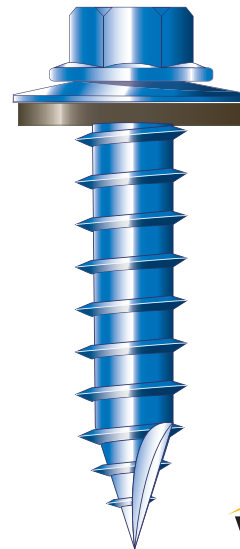

SCREW AND WASHER CODING	
T39	GB16
Screw Code	Washer Code
For unwashed simply use NW	
For 16mm washer simply use GB16	
For 29mm washer simply use GB29	

Techseal WASHER - GALVANISED BONDED			
Order Code	GB16	GB19	GB29

For Dekfast washers see page 22

HEXAGON COLOUR CAPS		
Order Code	HC3/HC5	HC6
To Suit	16mm and 19mm Washer	29mm Washer

Available in B.S. and RAL colours

WOODALL FS
FASTENING SYSTEMS

TECH
FASTENERS

WOODALL BS
BUILDING SYSTEMS

Liner Trays & Panels

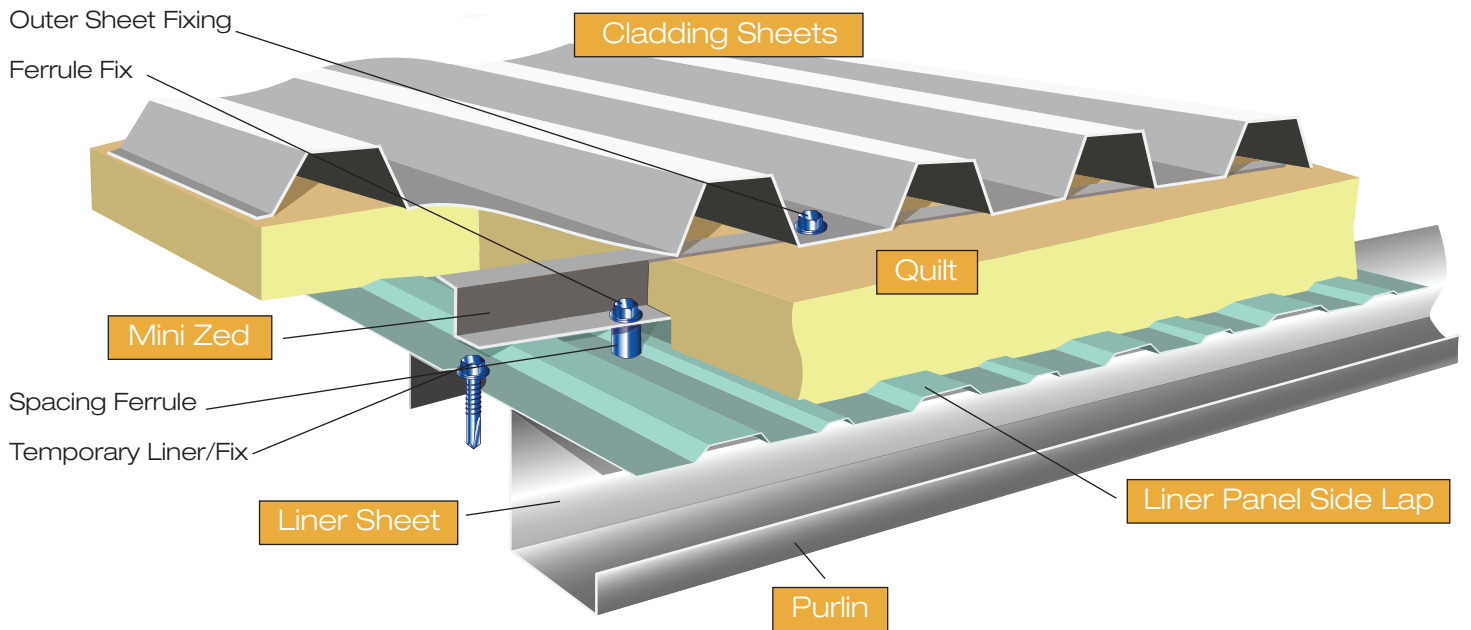

TEMPORARY LINER/FIX...

Order Code	T41NW	T32NW	T24NW
Purlin Thickness	1.2 - 2.8mm	4.0 - 7.5mm	6.0 - 12.5mm
ETL	11mm	11mm	20mm
Size	5.5 x 19mm	5.5 x 25mm	5.5 x 38mm

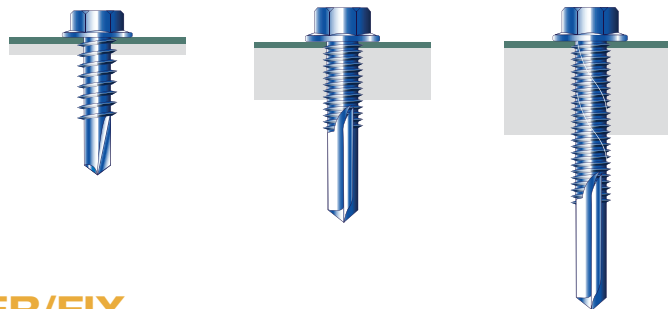

TEMPORARY LINER/FIX...

Order Code - Nylon	SPN22	SPN25	SPN30	SPN35	SPN42	SPN50
Order Code - Metal		SPM25			SPM42	SPM50
Length	22mm	25mm	30mm	35mm	42mm	50mm



Metal

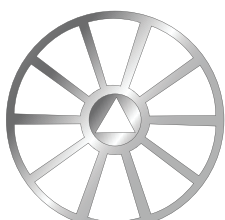

Nylon

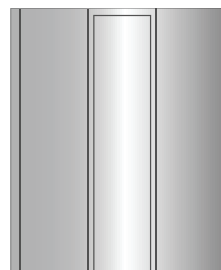
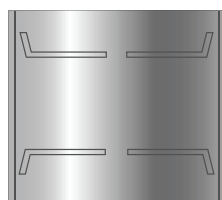

FERRULE FIXINGS...

Order Code	T12NW	T23NW	T38NW	T27NW	T33NW	NTL100NW
Size	55 x 43mm	55 x 57mm	55 x 70mm	55 x 60mm	55 x 80mm	55 x 100mm
Purlin Thickness	1.2 to 3.6mm			6.0 to 12.5mm		
Ferrule Length	22-25mm	25-42mm	50mm	22-25mm	42mm	50mm
ETL	33mm	46mm	64mm	42mm	58mm	82mm

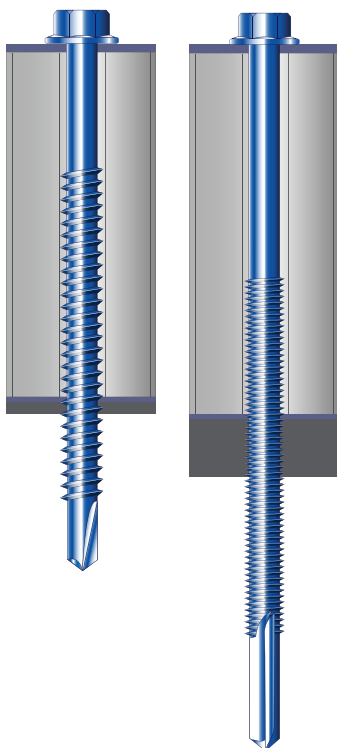

A range of fixings and ferrules suitable for all leading liner panel systems. The table shown illustrates correct selection of fixing and ferrule to accommodate the desired height of buildup.

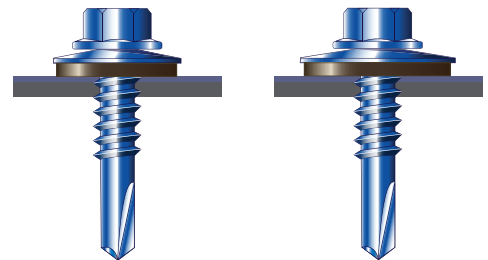

OUTER SHEET FIXINGS...

ROOF FIXINGS...

Order Code	T14GB19	T15GB19
SIZE	5.5 x 25mm	5.5 x 32mm
ETL	9mm	15mm

SIDE WALL / SHEET FIXINGS...

Order Code	T14GB19	T15GB19
SIZE	5.5 x 25mm	5.5 x 32mm
ETL	9mm	15mm

LINER PANEL SIDE LAPS...

Order Code	AD68 (AL4811)	1661/0619 (AL4818)	SD68SB
Size	4.8 x 11mm	4.8 x 18mm	4.8 x 12mm
Material	Aluminium	Aluminium	Steel
Grip Range	0.9mm to 6.4mm	0.9mm to 14.0mm	0.5mm to 6.4mm



High Threads for
Composite Panel Sheeting
to Light Purlins:
1.2 to 3.6mm and to Timber

Order Code	HT65GB19	HT85GB19	HT105GB19	HT120GB19
Size	5.5 x 65mm	5.5 x 85mm	5.5 x 105mm	5.5 x 120mm
ETL	50mm	70mm	90mm	100mm
Ins. Thickness	30-45mm	40-60mm	45-80mm	75-95mm

Order Code	HT130GB19	HT150GB19
Size	5.5 x 130mm	5.5 x 150mm
ETL	115mm	135mm
Ins. Thickness	70-105mm	90-120mm

Order Code	CPST14060GB19	CPST14080GB19	CPST14100GB19
Size	6.3 x 60mm	6.3 x 80mm	6.3 x 100mm
ETL	20mm	40mm	60mm
Ins. Thickness	upto 25mm	30-40mm	45-60mm

Order Code	CPST14125GB19	CPST14160GB19
Size	6.3 x 125mm	6.3 x 160mm
ETL	85mm	120mm
Ins. Thickness	80-85mm	80-110mm

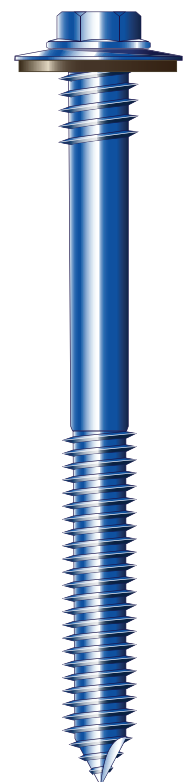

High Threads for Composite Panel Sheeting to Heavy Purlins: 6.0 to 12.5mm



Order Code	HTL76GB19	HTL102GB19	HTL110GB19	HTL130GB19
Size	5.5 x 76mm	5.5 x 102mm	5.5 x 110mm	5.5 x 130mm
ETL	56mm	82mm	86mm	110mm
Ins. Thickness	30-40mm	50-65mm	50-65mm	60-95mm



HEXAGON HEAD COLOUR CAPS		
Order Code	HC3/HC5	HC6
To Suit	16mm and 19mm Washers	29mm Washer
Product		

Available in B.S. and RAL colours

SCREW AND WASHER CODING	
HTL76	GB19
Screw Code	Washer Code
For unwashed simply use NW	
For 16mm washer simply use GB16	
For 29mm washer simply use GB29	

TECHSEAL ALUMINIUM WASHER			
Order Code	GB16	GB19	GB29
Product			

For Dekfast washers see page 22

Wing Drillers for Timber to Steel

Order Code	WDHS130	WDHS110	WDHS85	WDHS60	WDHS45
Size	5.5 x 130mm	5.5 x 110mm	5.5 x 85mm	5.5 x 60mm	5.5 x 45mm
Max. Timber Thickness	85mm	75mm	50mm	25mm	10mm
Max. Steel Thickness	6.0 - 12.5mm				

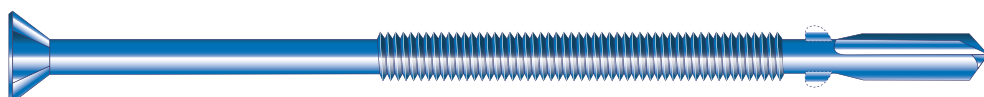

Order Code	WDLS110	WDLS85	WDLS60	WDLS50	WDLS38	WDLS25
Size	5.5 x 110mm	5.5 x 85mm	5.5 x 60mm	5.5 x 50mm	4.8 x 38mm	4.8 x 25mm
Max. Timber Thickness	86mm	63mm	43mm	28mm	20mm	5mm
Max. Steel Thickness	1.5 - 4.0mm					

FIBRE CEMENT SCREWS...FOR PURLINS 1.6MM TO 3.6MM

Order Code	SCF-BAZ63110	SCF-BAZ63125	SCF-BAZ63155
Size	6.3 x 110mm	6.3 x 125mm	6.3 x 155mm
ETL	75mm	95mm	125mm

Order Code	SCF-BAZ63175	SCF-BAZ63195
Size	6.3 x 175mm	6.3 x 195mm
ETL	145mm	165mm

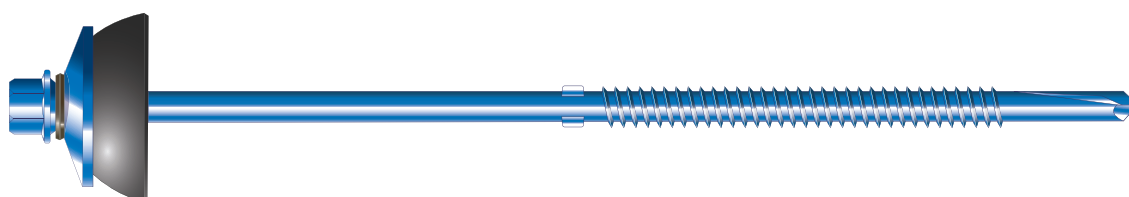

FIBRE CEMENT SCREWS...FOR PURLINS 6.0MM TO 12.5MM

Order Code	SCF5-BAZ63110	SCF5-BAZ63120	SCF5-BAZ63150
Size	6.3 x 110mm	6.3 x 120mm	6.3 x 150mm
ETL	75mm	85mm	115mm

Order Code	SCF5-BAZ63180	SCF5-BAZ63200
Size	6.3 x 180mm	6.3 x 200mm
ETL	145mm	165mm

FIBRE CEMENT SCREWS...FOR TIMBER PURLINS

Order Code	SCFT-BAZ6310
Size	6.3 x 130mm
ETL	100mm

Self Tapping Screws

CARBON STEEL

AB POINT FOR STEEL THICKNESS UP TO 3MM

Order Code	SCF
SC25	25mm
SC30	30mm
SC40	40mm
SC50	50mm
SC65	65mm
SC75	75mm
SC90	90mm
SC100	100mm
SC120	120mm
SC140	140mm

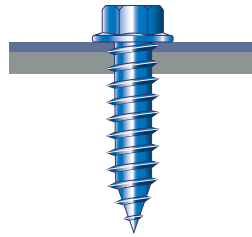

Material Thickness	Screw Type	Screw Diam	Hole Size
up to 1.0mm	AB	6.3mm	4.0mm
1.0 - 3.0mm	AB	6.3mm	4.9mm
3.0 - 4.5mm	AB	6.3mm	5.3mm
4.5 - 10.0mm	AB	6.3mm	5.8mm
10.0 - 12.0mm	AB	6.3mm	5.9mm

STAINLESS STEEL

AB POINT FOR STAINLESS STEEL THICKNESS UP TO 3MM

Order Code	SCF
SS25	25mm
SS30	30mm
SS40	40mm
SS50	50mm
SS65	65mm
SS75	75mm
SS90	90mm
SS100	100mm
SS120	120mm

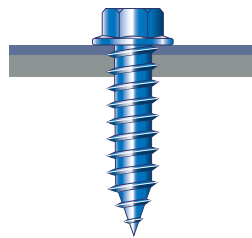

Material Thickness	Screw Type	Screw Diam
0.7 - 0.85mm	AB	3.95mm
0.8 - 1.25mm	AB	4.75mm
1.25 - 1.90mm	AB	5.05mm
1.90 - 3.0mm	AB	5.10mm

B POINT FOR STAINLESS STEEL THICKNESS UP TO 3MM

Order Code	SCF
STS25B	25mm
STS32B	32mm
STS38B	38mm
STS50B	50mm
STS65B	65mm
STS75B	75mm
STS90B	90mm
STS100B	100mm
STS125B	125mm

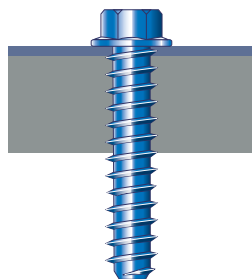

Material Thickness	Screw Type	Screw Diam
2.7 - 3.45mm	B	5.3mm
3.45 - 4.75mm	B	5.6mm
4.75 - 7.95mm	B	5.8mm
over 7.95	B	5.95mm approx



Screws - General Applications

SELF DRILLING SCREWS...

Order Code	Size	Head Size	ETL	Max Steel Thickness
T42NW	4.2 x 13	1/4" A/F	6mm	3.5mm
T48NW	4.2 x 19	1/4" A/F	12mm	3.5mm
T46NW	4.8 x 16	5/16" A/F	14.5mm	3.5mm
T49NW	4.8 x 19	5/16" A/F	10.5mm	4.5mm
T41NW	5.5 x 19	5/16" A/F	13.5mm	4.5mm
T14NW	5.5 x 25	5/16" A/F	19.5mm	4.5mm
T11NW	5.5 x 38	5/16" A/F	19.5mm	4.5mm

HEX HEAD CONCRETE MASONRY SCREWS...

Order Code	Size	Head Size	Plating
T3H32	4.8 x 32	7mm A/F	Rustpert
T3H45	4.8 x 45	7mm A/F	Rustpert
T3H57	4.8 x 57	7mm A/F	Rustpert
T4H32	6.3 x 32	5/16" A/F	Rustpert
T4H45	6.3 x 45	5/16" A/F	Rustpert
T4H57	6.3 x 57	5/16" A/F	Rustpert
T4H70	6.3 x 70	5/16" A/F	Rustpert
T4H82	6.3 x 82	5/16" A/F	Rustpert
T4H100	6.3 x 100	5/16" A/F	Rustpert

CSK HEAD CONCRETE MASONRY SCREWS...

Order Code	Size	Head Size	Plating
T3F32	4.8 x 32	Philips Recess	Rustpert
T3F45	4.8 x 45	Philips Recess	Rustpert
T3F57	4.8 x 57	Philips Recess	Rustpert
T4F32	6.3 x 32	Philips Recess	Rustpert
T4F45	6.3 x 45	Philips Recess	Rustpert
T4F57	6.3 x 57	Philips Recess	Rustpert
T4F70	6.3 x 70	Philips Recess	Rustpert
T4F82	6.3 x 82	Philips Recess	Rustpert
T4F100	6.3 x 100	Philips Recess	Rustpert
T4F125	6.3 x 100	Philips Recess	Rustpert

TECHFIX™

Washers

GALVANISED BONDED WASHERS...

Order Code	29GBW	19GBW	16GBW	14GBW	12GBW
Washer diam	29mm	19mm	16mm	14mm	12mm

STAINLESS STEEL BONDED WASHERS...

Order Code	29SBW	19SBW	16SBW	14SBW	12SBW
Washer diam	29mm	19mm	16mm	14mm	12mm

ALUMINIUM COMPOSITE WASHERS...

Order Code	32ACW	29ACW	19ACW	16ACW	12ACW
Washer diam	32mm	29mm	19mm	16mm	12mm

STAINLESS STEEL COMPOSITE WASHERS...

Order Code	29SCW	19SCW	16SCW
Washer diam	29mm	19mm	16mm

WASHER PULL OVER VALUES (kN)...

Washer Code	16GBW	19GBW	29GBW
0.5mm sheet	3.1	4.4	5.2
0.7mm sheet	5.8	5.7	6.9

WASHER PULL OVER VALUES (kN)...

Washer Code	12ACW	16ACW	19ACW	29ACW
0.5mm sheet	3.6	4.3	5.1	4.5
0.7mm sheet	5.0	5.5	5.3	5.0



Colour Matched Moulded Head Fixings

LIGHT & HEAVY SECTION SCREWS...

Order Code	T14GB16-MH--	T15GB16-MH--	T21GB16-MH--	T24GB16-MH--
Size	5.5 x 25mm	5.5 x 32mm	5.5 x 51mm	5.5 x 38mm
Purlin Thickness	1.2 - 3.6mm	1.2 - 3.6mm	1.2 - 3.6mm	6.0 - 12.5mm
ETL	6mm	11mm	36mm	17mm

For Moulded Headed Screws just add colour code on page 31 to the screw codes above.
(eg MH53 for Moulded Head Goosewing Grey)

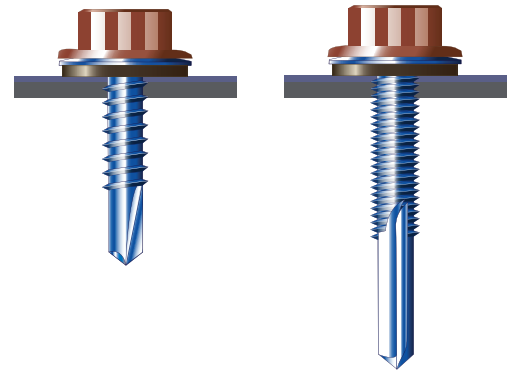

STITCHING & TIMBER SCREWS...

Order Code	T1427GB16-MH--	T39GB16-MH--
Size	6.3 x 27mm	6.3 x 32mm
ETL	3 sheets x 0.7mm	30mm

For Moulded Headed Screws just add colour code on page 31 to the screw codes above.
(eg MH53 for Moulded Head Goosewing Grey)

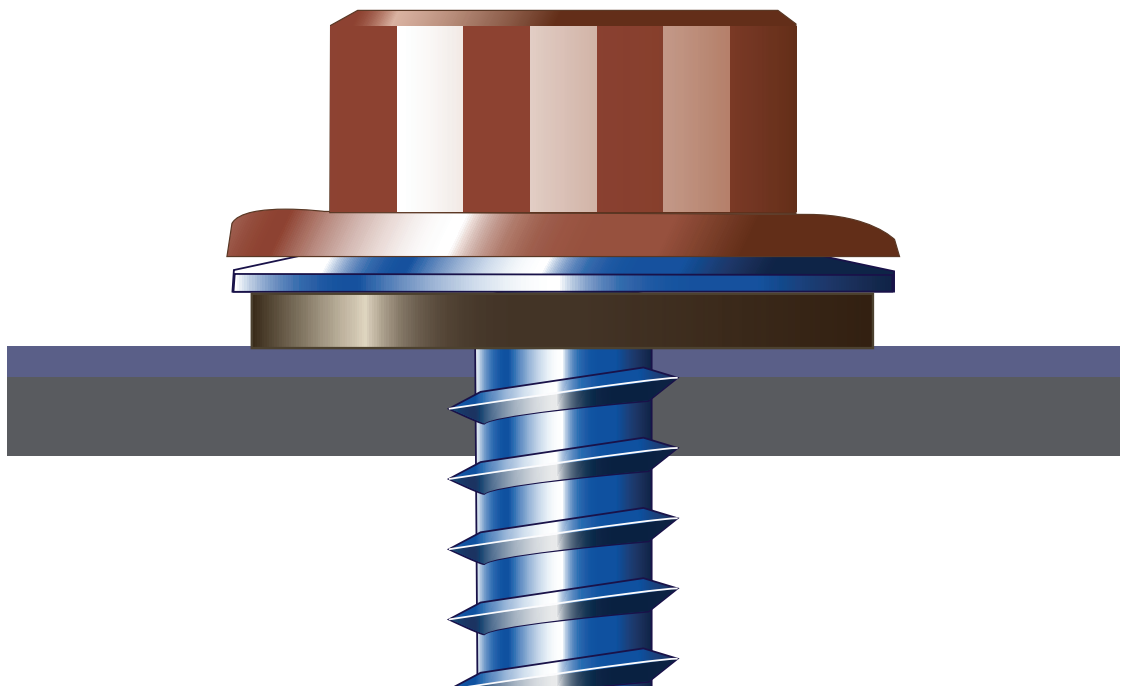
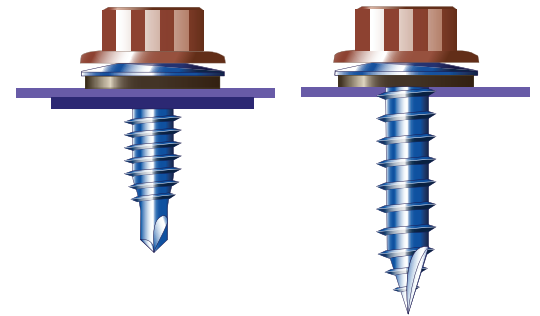

Colour Matched Moulded Head Fixings for Composite Panel

FOR PURLINS 1.5 - 3.6MM...

Order Code	HT85GB16-MH00	HT105GB16-MH--	HT120GB16-MH--
Size	5.5 x 85mm	5.5 x 105mm	5.5 x 120mm
ETL	70mm	90mm	100mm
Ins Thickness	40-60mm	45-80mm	70-95mm

FOR PURLINS 6.0 - 12.5MM...

Order Code	HT76GB16-MH--	HT102GB16-MH--	HT130GB16-MH--
Size	5.5 x 76mm	5.5 x 102mm	5.5 x 130mm
ETL	56mm	82mm	110mm
Ins. Thickness	30-40mm	50-65mm	60-95mm

For Moulded Headed Screws just add colour code on page 31 to the screw codes above.

(eg MH53 for Moulded Head Goosewing Grey)

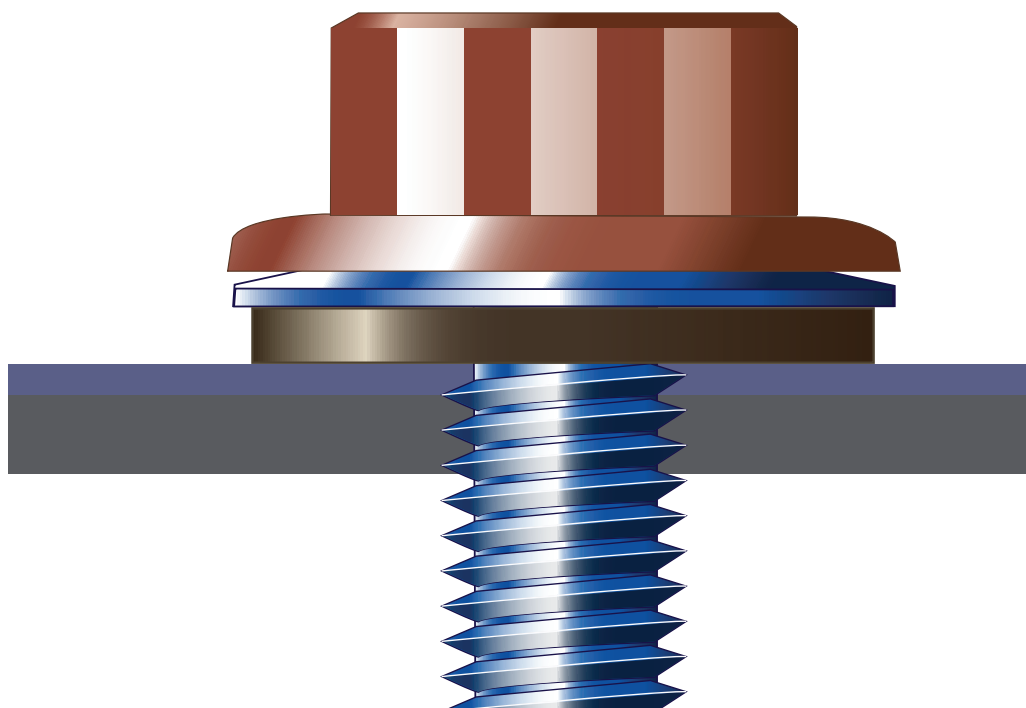
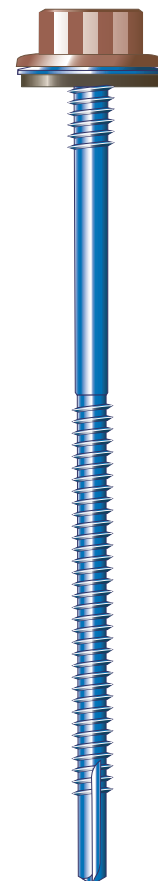

Low Profile Fixings

WFS offer low profile fixings for maximum aesthetic appeal on flashings and features. Available in self colour or powder coated to match your sheet, panel or flashing, the Torx drive recess facilitates a rapid and hassle free installation. A rubber washer is supplied assembled with the fixing to allow a watertight seal and retain the visual benefits of using a low profile screw.

Order Code	LPLS25
Size	5.5 x 25mm
ETL	6mm

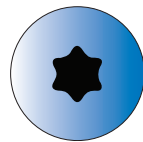
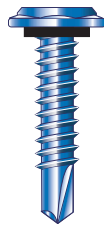

Order Code	LPST22
Size	6.3 x 22mm
ETL	2 Sheets x 1.25mm

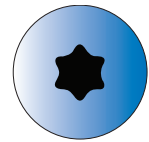
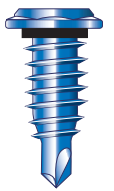

Order Code	LPLS25-PH--
Size	5.5 x 25mm
ETL	6mm

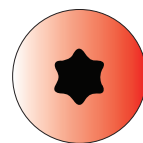
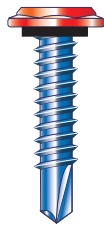

Order Code	LPST22-PH--
Size	6.3 x 22mm
ETL	2 Sheets x 1.25mm

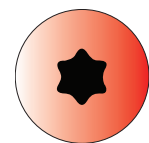
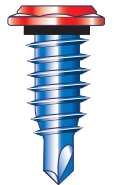

Other lengths available upon request.
Please contact sales for further information

Low Profile Stainless Steel Fixings

For use with aluminium flashings or in other situations where lifespan of fixing is paramount, we offer our low profile fixing in A2 304 grade austenitic stainless steel. Supplied with a rubber washer and available in RAL and BS matched powder coated colours.

Order Code	BMLPLS25
Size	5.5 x 25mm
ESL	10mm

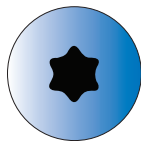
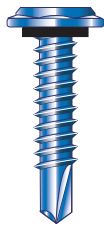

Order Code	BMLPST22
Size	6.3 x 22mm
ESL	11mm

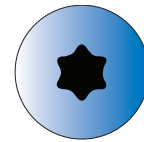
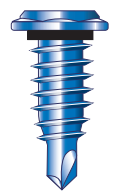

Order Code	BMLPLS25-PH--
Size	5.5 x 25mm
ESL	10mm

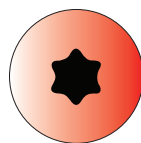
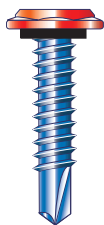

Order Code	BMLPST22-PH--
Size	6.3 x 22mm
ESL	11mm

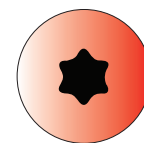
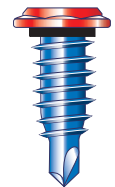

Other lengths available upon request.
Please contact sales for further information

Pan Head Decking Screws for Metal Deck

A range of screws for fixing rigid insulation board to steel deck 0.7-1.6mm thick. This range is black plated and is proven to withstand up to 40 Kesternich test cycles. The Phillips no.3 truss head is complimented by the 75mm diameter round pressure plate.

Order Code	TFDP55040	TFDP55057	TFDP55073	TFDP55083	TFDP55095
Size	5.5 x 40mm	5.5 x 57mm	5.5 x 73mm	5.5 x 83mm	5.5 x 95mm

Order Code	TFDP55115	TFDP55125	TFDP55150	TFDP55178
Size	5.5 x 115mm	5.5 x 125mm	5.5 x 150mm	5.5 x 178mm

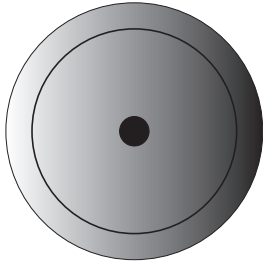
Order Code	TFMP3
75mm Diameter Round Steel Pressure Plate	

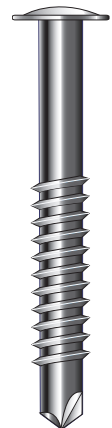

Please speak to our sales team for advice on the most suitable fixing length for your application.

Fixing Length (mm)	Thread Length (mm)	Min. Buildup Height (mm)	Max. Buildup Height (mm)
40	40	12	15
57	57	12	32
73	73	12	48
83	73	22	58
95	73	34	70
115	100	27	90
125	100	37	100
150	100	62	125
178	100	90	153

Pan Head Decking Screws for Timber and Concrete Deck

This heavy duty range of screws is used for fixing rigid insulation board to timber and concrete. The black plating has been tested and proven to withstand up to 30 cycles of Kesternich testing. A 75mm diameter round pressure plate can be used in conjunction with this fixing.

Order Code	TFDP63075	TFDP63100	TFDP63125	TFDP63150	TFDP63178
Size	6.3 x 75mm	6.3 x 100mm	6.3 x 125mm	6.3 x 150mm	6.3 x 178mm

Order Code	TFDP63200	TFDP63225	TFDP63250	TFDP63300	TFDP63350
Size	6.3 x 200mm	6.3 x 225mm	6.3 x 250mm	6.3 x 300mm	6.3 x 350mm

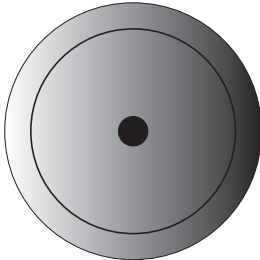

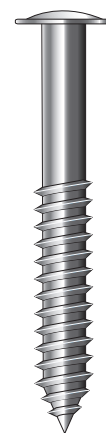





Order Code	TFMP3
75mm Diameter Round Steel Pressure Plate	



Please speak to our sales team for advice on the most suitable fixing length for your application.

Fixing Length (mm)	Thread Length (mm)	Rec. For Concrete Thickness (mm)	Max. Buildup For Fixing To Timber (mm)
75	75	50	25
100	100	75	50
125	125	100	75
150	97	125	100
178	97	153	128
200	97	175	150
225	97	200	175
250	97	225	200
300	97	275	250
350	97	325	300

Steel Framing Systems can be used in the construction of all types of buildings. The system comprises of a range of studs, joist sections and runners which are assembled to form the “skeleton” of the structure. Then typically using a combination of accessories, insulation and boards to complete the rest of the basic structure. According to the connection type required, the appropriate fastener can be selected from the guide below.

Application	Description	Drive Bit	Part Code	
Min 1.2mm to max 3.0mm cold rolled	Low profile head 4.8mm x 22mm Tek2	Phillips No.2	WAFFERHEAD48022	
Mix 3.0mm to Max 12.5mm hot rolled	Hex head 5.5mm x 32mm Tek5	5/16" A/F Hex	T47NW	
Min 1.5mm to max 2.0mm cold rolled	Hex head 4.8mm x 16mm Tek3	5/16" A/F Hex	T46NW	
1No. Layer 15mm plasterboard to max 3.0mm cold rolled	Bugle head 42mm length	Phillips No.2	7703542	
1No. Layer 15mm plasterboard to max 12.5mm hot rolled	Countersunk head 5.5 x 60mm Tek5	Phillips No.3	WDHS60	
2No. layer 15mm plasterboard to max 3.0mm cold rolled	Countersunk head 5.5 x 85mm Tek3	Phillips No.3	WDLS85	
2No. layer 15mm plasterboard to max 3.0mm cold rolled	Bugle head 50mm length	Phillips No.2	7703550	
2No. layer 15mm plasterboard to max 12.5mm cold rolled	Countersunk head 5.5 x 60mm Tek5	Phillips No.3	WDHS60	
Up to 6mm sheathing board to max 3.0 cold rolled	Countersunk head 4.8mm x 38mm Tek3	Phillips No.2	WDLS38	
Up to 22mm sheathing board to max 3.0 cold rolled	Countersunk head 5.5mm x 50mm Tek3	Phillips No.2	WDLS50	
Up to 46mm rigid foam insulation to max 3.0mm cold rolled	Countersunk head 5.5mm x 50mm	Phillips No.2	WLLS50	
1.5mm brick-tie channel through 29mm rigid foam insulation to max 3.0mm cold rolled	Hex Head 5.5mm x 65mm high thread Tek3	5/16" A/F Hex	HT65GB16	
1.5mm brick-tie channel through 46mm rigid foam insulation to max 3.0mm cold rolled	Hex Head 5.5mm x 80mm high thread Tek3	5/16" A/F Hex	HT85GB16	
Up to 3.0mm cold rolled to concrete	Wedge Anchor	N/A	3CAV6X40CA	
Up to 40mm timber to maximum 3.0 cold rolled	Countersunk head 5.5mm x 60mm Tek3	Phillips No.3	WDLS60	
General framing screw for studs, joist runners and bracing sections to 3mm max build up	4.8 x 16mm low profile head	Phillips No.2	LP1016	
Heavy duty box sections etc. Material build up over 4mm	5.5 x 38mm low profile head	Phillips No.3	LPHS38	
Composite structural details-gusset plates, angle brackets etc	5.5 x 25mm hex head	5/16" A/F Hex	T14NW	
Runners to concrete and structural concrete block	6.0 x 32mm hex head	5/16" A/F Hex	T4H32	
Metsec Section 3.5mm thick to steel up to 12.5mm thick	5.5 x 38mm hex head	5/16" A/F Hex	T24-10NW	

25 / 15 Frame Fix Channel

25/15 Frame Fix Channel has been developed in response to the increasing need to tie masonry cladding back to steel framed structures.

The design facilitates the fixing back using self-drill screws (normally at 450mm vertical centres) without crushing the insulation.

Fix the 25/15 frame fix channel at 450mm centres. Pre-pierced holes are provided at 112.5mm centres, this aids site cutting and avoids excessive channel cantilever past the last fixing point.

Once fixed, the channel is then ready to accept the 4000 range of channel tie. These are quickly 'twist fixed' into the channel at any position as work proceeds.

We recommend that all wall ties achieve a minimum embedment of 62.5mm in the outer leaf of brickwork.

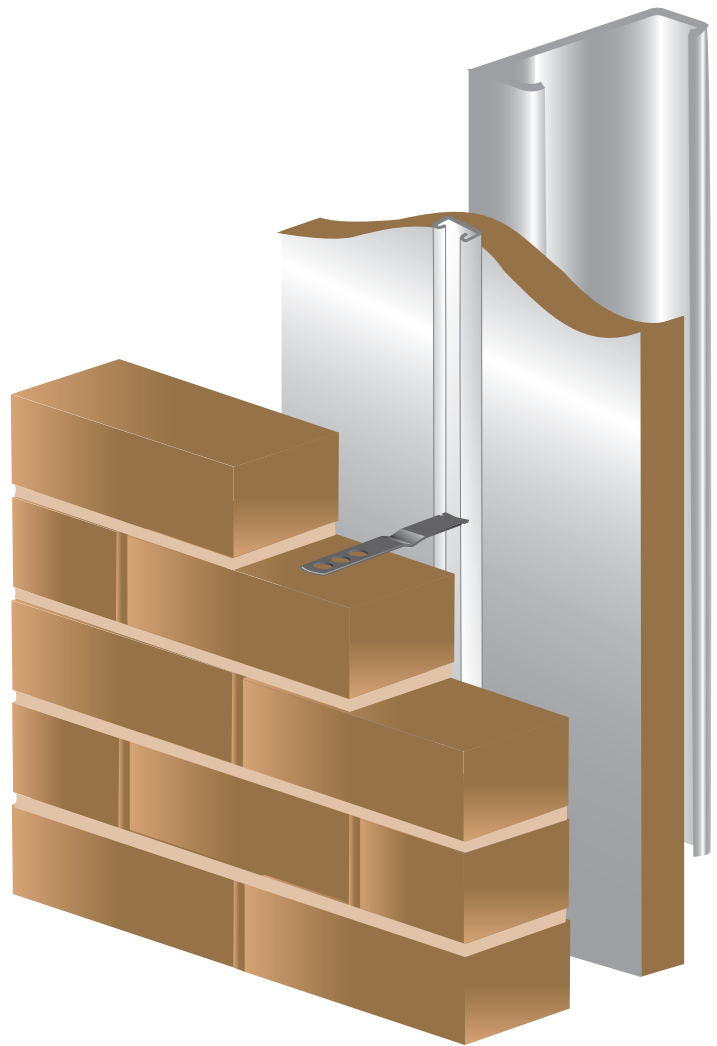

4000 Channel Tie
available upon request

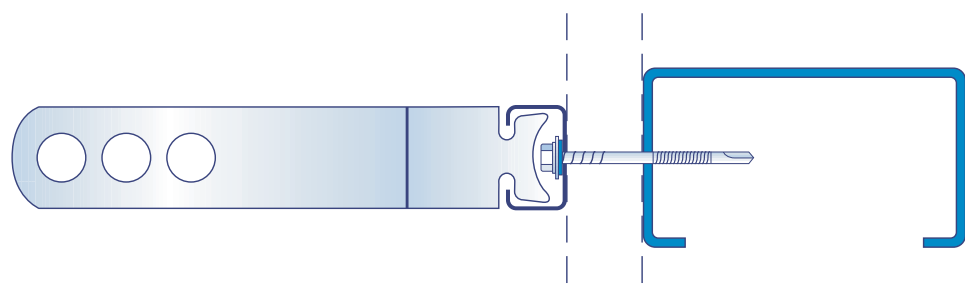
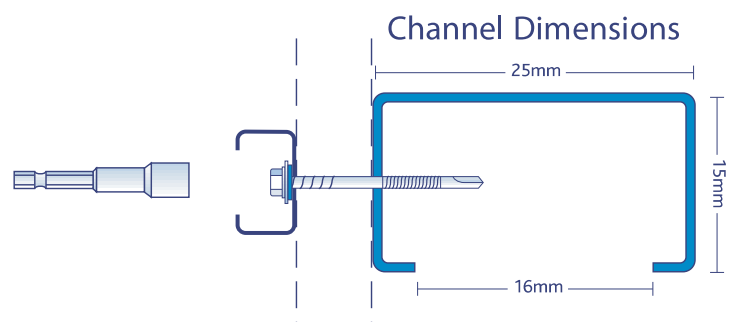

Colour Codes for Caps & Moulded Head Screws

Woodall Colour Caps and Nylon Moulded Head Screws are available in the following BS and RAL colour codes (non standard colours are also available on request)

Colour Name	British Std Ref.	RAL Ref.	EFS Codes
Acorn Brown	08 D 45		01
Bahama Blue		5015	09
Mountain Blue		5014	14
Solent Blue	18 E 53		21
Glen Green		1002	42
Linden Green	12 E 53		43
Pinewood Green	14 C 39		45
Verona Green	14 E 53	6029	47
Alaska Grey		7000	49
White	00 E 55	9010	51
Goosewing Grey	10 A 05	7038	53
Merlin Grey	18 B 25		55
Black	00 E 53	9005	58
Terracotta Red	04 C 39	8004	59
Juniper Green	12 B 29		60
Slate Grey		7012	63
Svelte Grey	10 B 23	7034	65
Mushroom	10 B 19	1013	68
Moorland Green	12 B 21		69
Olive Green	12 B 27		70
Wedgewood Blue	18 C 37		71
Jade	14 B 37		75
Van Dyke Brown	08 B 29	8025	79
Oyster		7035	81
Bamboo	08 C 35		82
Burnt Orange	06 D4 5	6021	83
Ocean Blue	18 C 39	5001	84
petra	04 D 44	3016	85
Slate Blue	18 B 29		86
Saffron	08 E 53		92
Metallic Silver			94
Poppy Red	04 E 53	2002	96
Tangerine Orange	06 E 53	2000	99
Aztec Yellow	10 E 55	1023	104
Golden Glow	08 E 51	8023	106
Meadowslands	12 B 17		121
Hertiage		6002	122
Honesty	10 C 31		123
Britannia	18 E 58		126
Albatros	18 B 17		128
Dijon Mustard	10 D 44	1027	131
Eau De Nil	14 E 49		143
Hamlet		9002	15
Sargasso		5003	178
Burano		3004	183

Insulation Hangers

Self Adhesive Insulation Hangers

Self Adhesive hangers are designed to fix insulation materials to smooth surfaces such as airducts, attenuators, chambers and enclosures. Their use allows a speedy fix without risk of corrosion. The adhesive foam backing is of the highest quality and the locking CLIM fastener clips ensure an outstanding assembly. In order to meet all requirements we offer you a wide range of pin lengths.

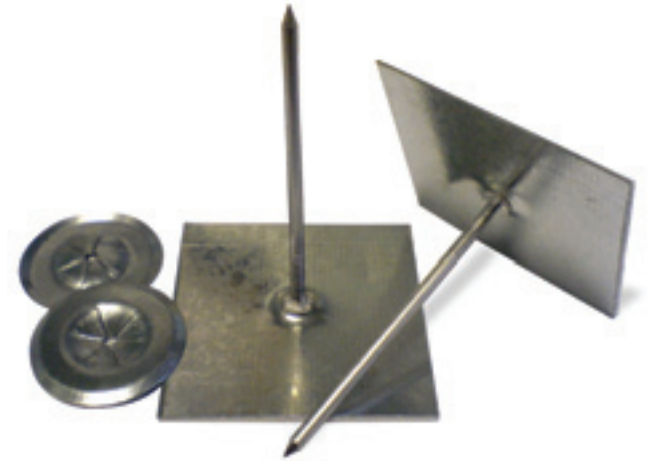

INSULATION HANGERS

Order Code	SIZE	Box Qty
IH40	40mm	500
IH62	62mm	500
IH89	89mm	500
IH114	114mm	500
IH140	140mm	250
IH165	165mm	250
IH203	203mm	250

Operating Instructions for Insulation Hangers

1. Install at ambient temp. above 10°C (preferably between 15°C and 25°C)
2. Surfaces must be clean, dry and free of dust, grease, oil and any loose materials
3. Remove the protective release paper taking care NOT to touch adhesive
4. Place the hanger in the required position and press the base against the surface to be insulated
5. Insulation can be impaled immediately and firmly locked with fastening clips but maximum strength of adhesive is achieved 24 hours after installaion

Tapes, Sealants & Silicones

SPECIALIST TAPE...

ALUMINIUM FOIL TAPE

Order Code	Size	Box Qty (rolls)	Mtrs per roll
ALUFT50	50mm	24	45
ALUFT75	75mm	16	45
ALUFT100	100mm	12	45

BARRIER TAPE (PVC) GREY

Order Code	Size	Box Qty (rolls)	Mtrs per roll
BARTG50	50mm	24	33
BARTG75	75mm	16	33
BARTG100	100mm	12	33

BUTYL MASTIC SEALANT...

BUTYL LAPSTRIP

Order Code	Size	Box Qty (rolls)	Mtrs per roll
LAP6X2	6x2mm	30	22.5
LAP9X1.5	9x1.5mm	24	30
LAP9X3	9x3mm	24	15
LAP19X3	19x3mm	14	15
LAP25X6	25x6mm	15	5
LAP6X5	6x5mm	30	9.6

BUTYL BEAD SINGLE COIL

Order Code	Size	Box Qty (rolls)	Mtrs per roll
4MMBEAD	4mm	30	12
6MMBEAD	6mm	24	8
8MMBEAD	8mm	20	6

POLYBAND WHITE

Order Code	Size	Box Qty (rolls)	Mtrs per roll
POLYBAND	50x1.5mm	6	35

GUN APPLIED BUTYL SEALANT

Order Code	Size	Box Qty (rolls)	Cartridge Size
ELASTOFIL	As cut	24	380ml

EPDM SEALING TAPES

B27 EPDM DRY SEAL - BLACK

Order Code	Size	Box Qty (rolls)	Mtrs per roll
B27B10X2	10x2mm	10	10
B27B10X4	10x4mm	10	10
B27B25X3	25x3mm	5	10
B27B25X6	25x6mm	5	10
B27B50X3	50x3mm	3	10



Tapes, Sealants & Silicones

EXPANDING FOAM TAPES...

EXPANDING FOAM TAPE - BLACK

Order Code	Size	Box Qty (rolls)	Mtrs per roll
EXPFT25X6	25x6 (Max EXP. 30mm)	19	5
EXPFT25X10	25x10 (Max EXP. 50mm)	19	3

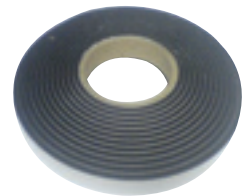

FLASH & SEAL

Order Code	Size	Box Qty (rolls)	Mtrs per roll
FLASH100	100mm flash & seal	12	10
FLASH150	150mm flash & seal	8	10
FLASH225	225mm flash & seal	4	10
FLASH300	300mm flash & seal	4	10
FLASHPR	Premier flash & seal		1 Lt. Tin

SILICONE, SEALANTS, PAINT & PASTE

HIGH MODULUS 10/20 SILICONE

Order Code	Colour	Box Qty (Tubes)	Size of tube
SIL10/20CL	Clear	25	310ml
SIL10/20WH	White	25	310ml
SIL10/20AL	Silver	20	310ml



LOW MODULUS 10/25 SILICONE

Order Code	Colour	Box Qty (Tubes)	Size of tube
SIL10/25CL	Clear	25	310ml
SIL10/25WH	White	25	310ml
SIL10/25BL	Black	25	310ml
SIL10/25GR	Grey	25	310ml



GUN GRADE MASTIC 10/30

Order Code	Colour	Box Qty (Tubes)	Size of tube
5MASGPBR	Brown	25	310ml
5MASGPWE	White	25	310ml
5MASGPGY	Grey	25	310ml

PVC SEALER PASTE

Order Code	Colour	Box Qty (Tubes)	Size of tube
R24A-COLOUR	Paste-BS Col Range	40	132g



PVC TOUCH UP PAINT

Order Code	Colour	Box Qty (Tins)	Size of tin
PVCPAINT-colour	Paint-BS Col Range	N/A	1/4 LTR

Foam Fillers

Woodall Fastening Systems are able to offer any profile with a rapid delivery time. We can also offer a fast production lead time for special applications.



Types Available

- All standard sheeting profiles
- Rake cut - available in block or continuous
- Double profile
- Ventilated
- Adhesive mastic to profile and/or base
- Extra wall height or extra wide profile
- Straight cut blocks cut to your specification

MATERIALS AVAILABLE

POLYETHYLENE (PEL)

Produced from closed cell and cross linked expanded polyethylene which is CFC and HCFC free. This product has greater rigidity than most foams and is ideal for sealing profiled sheeting.

SPECIFICATION

Density	Colour	Life Expect
33Kg / m3	Black, White or Black & White reversable	15 years plus

EPDM SYNTHETIC RUBBER (BSR)

Produced from Ethylene Propylene Diene Monomer (EPDM) rubber. It is closed cell and cross linked while being CFC and HCFC free. This product has many of the desirable properties of natural rubber, but with complete weather and ozone resistance. BSR grade is capable of remaining fully effective across a wide temperature band. Outdoor exposure and accelerated tests indicate that this material appears unaffected by weather, ozone and normal ultra-violet light.

SPECIFICATION

Density	Colour	Life Expect
100-150Kg / m3	Black or White	20 years plus

Pipe Flashings

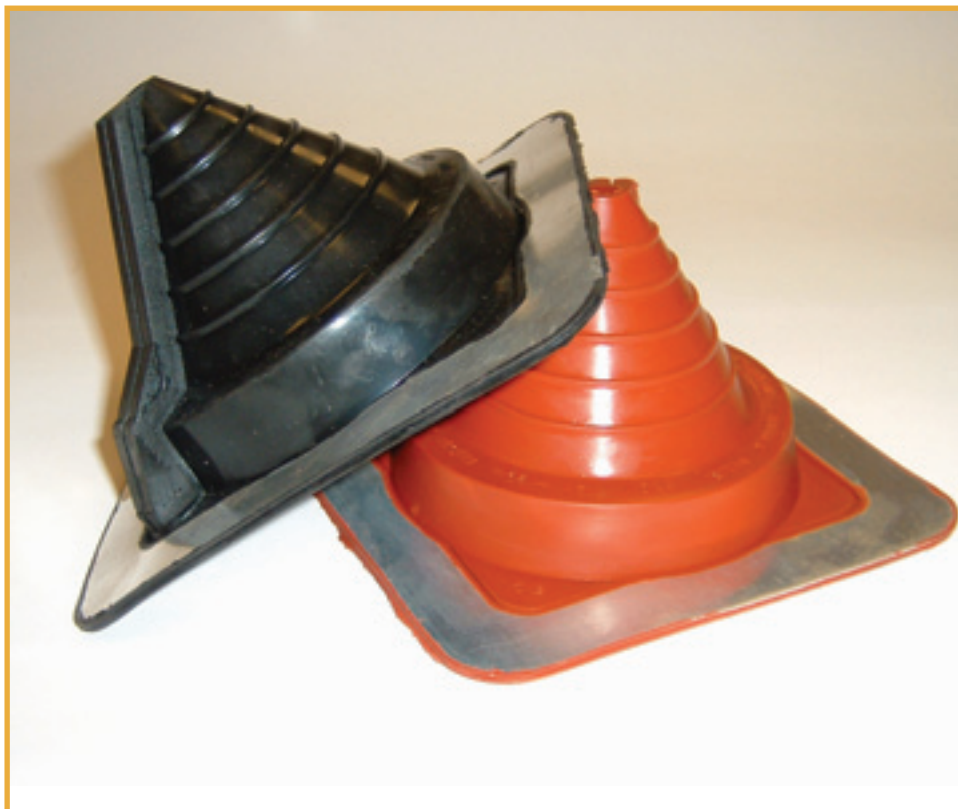

Pipe Flashings

Flexible Base - easily formed to match sheet profile

Adaptability - suits either std. or retrofit applications

EPDM or Silicone Rubber - to suit cold or hot pipes

Simple to fit - sleeve marked with pipe diameters

Square Base - facilitates easy installation

Temperature Ranges EPDM = -40° to 115° Silicone = -60° to 240°

Order code

Pipe Diameters (mm)

EPDM -Black	Silicone - Red	0 - 25 degree roof pitch	0 - 45 degree roof pitch	Base dimensions	Number of RFC clips for retrofit applications
PFD1E	PFD1S	3 - 25	3 - 20	75 x 75	N/A
PFD2E	PFD2S	10 - 90	10 - 70	155 x 155	5
PFD3E	PFD3S	40- 100	40 - 90	203 x 203	5
PFD4E	PFD4S	75 -150	75 - 135	254 x 254	6
PFD5E	PFD5S	125 - 200	125 - 180	305 x 305	6
PFD6E	PFD6S	145- 250	145 - 230	356 x 356	7
PFD7E	PFD7S	195 - 300	195 - 250	432 x 432	7
PFD8E	PFD8S	275 - 380	275 - 355	540 x 597	9
PFD9E	PFD9S	315 - 500	315 - 450	650 x 720	11
PFD10E	PFD10S	400 - 630 (750)	400 - 500	965 x 995	15

Fixings, Drill bits, Caps and Silicone to fix pipe flashings are all available - Please ask our Sales Team for assistance

Makita 6802BV



Self Drilling Screw Gun
570 Watt Motor
"Set and Forget" nose piece for consistent fastener depth
No Load Speed 0 - 2,500 rpm
Net Weight 1.5Kg
Includes Carrying Case and 5/16 Magnetic Socket

Dewalt DW263K



Self Drilling Screw Gun
540 Watt Motor
"Set and Forget" nose piece for consistent fastener depth
No Load Speed 0 - 2,500 rpm
Net Weight 1.3Kg
Includes Carrying Case and 5/16 Magnetic Socket

FEIN BLK1.3CS

Power Nibbler
350 Watt Motor
Strokes at 1800 RPM
Net Weight of 1.75kg
Radius os smallest curve (inside / outside) 15/20mm

Metabo DWSE 6.3



Self Drilling Screw Gun
550 Watt Motor
Fully Adjustable Depth Stop
No Load Speed 0 - 2,100 rpm
Net Weight 2.0Kg
Includes Carrying Case and 5/16 Magnetic Socket

Evolution 230



Steel Cutting Saw
1750 Watt Motor
Maximum Box Cutting Capacity (6mm Wall) - 84mm
Maximum Cutting Thickness in Steel Plate - 12mm
Blades for Wood, Aluminum and Steel Available
Also available in 180mm Blade

Metabo KN6875



Power Nibbler
550 Watt Motor
Stokes per minute at no load = 3000 rpm
Stokes per minute at rated load = 1800 rpm no load = 3000 rpm
Net Weight 2.1Kg
Minimum Curve Radius 4mm

Dewalt DW5113K



SDS Hammer Drill
110/240V SDS Heavy Duty Hammer Drill
800 Watt with reverse
Rotation stop for light chiselling applications
Electronic variable speed for total control
Impact energy 0 - 3.4 joules

Dewalt DW309K



Reciprocating Saw
Keyless Blade change & fast cutting with 32mm stroke length
1025 Watt Motor
Max cutting capacity (wood) 275mm
Max cutting capacity (steel) 117mm
Max cutting capacity (uPVC) 150mm

TECHFIX™

Accessories

MAGNETIC SOCKETS C/W EXT. PIECE...

HEX HEAD SOCKETS...

Order Code	Size	Overall Length	No. Per Box
M1PEX07	7mm	65mm	20
M1PEX08	1/4"	65mm	20
M1PEX10	5/16"	65mm	20
M1PEX12	3/8"	65mm	20



BI-HEX HEAD SOCKETS (TO SUIT MOULDED HEAD SCREWS)...

Order Code	Size	Overall Length	No. Per Box
BIHEXSOCKET	11mm	65mm	20



STUB BIT HOLDER...

Order Code	Size	Overall Length	No. Per Box
2BITHOLDS	11mm	65mm	20



STUB BITS...

STUB BITS (1/4" DRIVE)...

Order Code	Size	Overall Length	No. Per Box
2BITHP1	No.1 Philips	25mm	100
2BITHPH2	No.2 Philips	25mm	100
2BITHP3	No.3 Philips	25mm	100

2BITPZ1	No.1 Pozi	25mm	100
2BITPZ2	No.2 Pozi	25mm	100
2BITPZ3	No.3 Pozi	25mm	100



440-1-SLT	No.1 Slotted	25mm	100
440-2-SLT	No.2 Slotted	25mm	100
440-3-SLT	No.3 Slotted	25mm	100





Galvanised Drive Screws

14g x 75 14g x 100 18g x 125



Hooks Bolts - Standard / square Bend (Plated mild Steel or Stainless Steel)

M6 x 100mm to 200mm M8 x 60mm to 300mm



U Bolts - Standard / Extended

Standard Leg in BZP available in sizes from 15mm (1/2") to 200mm (8")
Extended Leg in BZP available in sizes from 15mm (1/2") to 150mm (6")



Square / Hex Full Nuts

Hex Full Nuts to DIN 934 available from M4 to M24
Square Nuts available in M6, M8 & M10
Other types of nuts available on request including Locknuts, Brass & Self Color.



Roofing Bolts and Nuts

M6 available in lengths from 8mm to 200mm
M8 available in lengths from 8mm to 200mm
Gutter Bolts also available on request



"Dowty" Spat Washers and Topats

Washers available in M6 & M8
Topats available in M6 & M8



Sealing Washers, Covers, Nuts and Caps

M6 x 20mm & M6 / M8 x 28mm Sealing Washer
20mm / 28mm Shallow Sealing Cover & 28mm Deep Sealing Cover
M6 / M8 x 28mm Sealing Type Nut
M6 & M8 Sealing Type Cover

Saddle Washers

Available in M6 & M8



Round Flat Washers

Penny Washers available in M6 to M20
DIN 125A Steel Flat Washers available in M6 to M20



Drill Bits

HSS Drill Bits available from 2.0mm to 20.0mm
SDS Drill Bits available from 4.0mm to 24.0mm and up to 400mm in length
RID Masonry Bits available from 4.0mm to 24mm and up to 400mm in length
135° split point drill bits

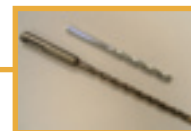

Twinthread and Chipboard Woodscrews

Twinthread Woodscrews available in No.4 x 1/2" to No.12 x 4" with BZP plating
Chipboard Woodscrews available in 2.5 x 12mm to 6.0 x 200mm in ZYP plating
All Woodscrews are small packed and available in many head styles



Collated and Boxed Drywall Screws

Collated Drywall available in Fine and Coarse Thread and Phosphate and Zinc Plating
Boxed Drywall available in Fine and Coarse Thread and Phosphate and Zinc Plating
Self Drill Drywall and Wafer Head Screws also available



Concrete Anchors and Nylon Frame & Hammer Fixings

Shield & Sleeve Anchors Through Bolts
Nylon Frame & Hammer Fixings Nylon Window Frame Anchors



WOODALL FS
FASTENING SYSTEMS

TECH
FASTENERS

WOODALL BS
BUILDING SYSTEMS



Woodall Fastening Systems
Unit 30, Navigation Drive, Hurst Business Park, Brierley Hill,
West Midlands. DY5 1UT. England



Tech Fasteners Ltd.
Unit 18/2, Clondalkin Industrial Estate,
Dublin 22, Ireland