

PURLINS, RAILS & EAVES BEAMS

> DESIGN GUIDE

ZED PURLIN SYSTEMS › EAVES BEAMS ›
ZED & CEE SHEETING RAILS › FLOOR CEES



PURLINS, RAILS & EAVES BEAMS

Index	
About Steadmans	03
Introduction	03
Specification	03
Requirements.....	03
Overview.....	04
Zed and Cee section range	06
Zed Purlin Systems	07
Sleeved single span system	07
Sleeved double span system.....	07
Heavy end-bay single span system	07
Heavy end-bay double span system.....	07
Sleeved purlin system.....	08
Butted single span system.....	08
Butted purlin system	08
Roof sag-system requirements	09
Roof sag bar system.....	10
Roof angle brace system	10
Mono pitch roofs.....	11
Steep pitch roofs.....	12
Shallow pitch roofs	12
Long roof slopes	13
Curved roofs.....	13
Tiled roofs.....	14
Cantilever purlins	15
Eaves Beams	16
Sections	16
Typical eaves beam details.....	17
Typical connections to column heads	17
Connections between eaves beams and rail struts.....	18
Zed and Cee Sheeting Rails	19
Sleeved system.....	19
Butted system	19
Double span system (brick restraint).....	19
Sleeved rail system	20
Butted & double span rail system.....	21
Typical brick restraint details.....	21
Sheeting rail sag-system requirements	22
Sheeting rail sag system.....	23
Horizontal wall cladding requirements	24
Fire Rated Boundary Walls.....	25
Additional Details	26
Typical Zed section details (Cee sections similar)	26
Parapet framing	27
Valley beam details	28
Door & window framing	29
Suspended services & point loads	30
Suspended ceilings.....	31
Detailing Information	32
Zed purlin and rail hole punching details	32
Cee rail hole punching details	33
Fire wall rail hole punching details	34
Standard cleats for purlins & rails	35
Anti-sag system components	36
Cleats	37
Miscellaneous components	38
Custom sections	39
Technical support	40
References	41

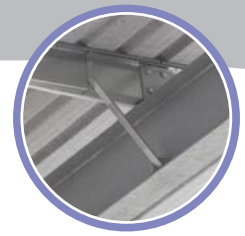

ABOUT STEADMANS

A Steadman & Son Limited (usually known as Steadmans) are one of the UK's leading manufacturers of roofing and cladding, supplying high quality cladding materials from our sites in England, Scotland and Northern Ireland. We offer total roofing and cladding solutions which we deliver with our dedicated haulage fleet.

Our continuous investment programme and on-going product development ensures we can provide high quality products promptly and at competitive prices.

INTRODUCTION

This brochure contains details of our increased range of Zed, Cee and Eaves Beam sections and accessories.

Section profiles and dimensions are included along with structural properties, detailing information and typical construction details.

The new section range offers complete compatibility between Zed and Cee sections sizes.

The products are formed from hot dipped galvanised steel coil to BS EN 10346:2009 Fe E390G -Z275.

The sections are designed to BS EN 1993-1-3:2006 using a combination of rational analysis and component testing.

A separate brochure containing load tables for the Purlins, Rails & Eaves Beams is also available from Steadmans upon request or as a download from our website.

Steadmans realise that our standard range will not meet all requirements and therefore customer designed Zed, Cee and Eaves Beam sections can be manufactured along with individual designs for special applications.

Our extensive stock of full width coils in various gauges and our capability to cut, fold and punch these materials allow us to offer solutions to almost all situations.

Please consult Steadmans Sales Department for further details.

SPECIFICATION

NBS Plus is a library of technical product information written in NBS format, linked to NBS clauses and clause guidance.

With NBS Plus, specifiers can select products quickly and accurately then drop the product information directly into a specification.

NBS clauses for Zed, Cee and Eaves Beam sections and other Steadmans products are now available for NBS subscribers.

REQUIREMENTS

Zed, Cee and Eaves Beam sections are manufactured in a process certified to ISO 9001:2008.

Installation warranty

Steadmans offer an independent audit-based warranty for Zed, Cee and Eaves Beam sections.

The QA+ warranty, from Auditing Workmanship & Materials Ltd, provides pre-site and on-site quality inspections and audits to ensure the high standards of construction and finishing which will maximise service life and reduce maintenance costs.

The QA+ warranty can be extended to a ten year insurance backed warranty covering defects arising from poor workmanship, defective materials and damage resulting from design defects. Contact Steadmans for more information about the warranties.



PURLINS, RAILS & EAVES BEAMS OVERVIEW

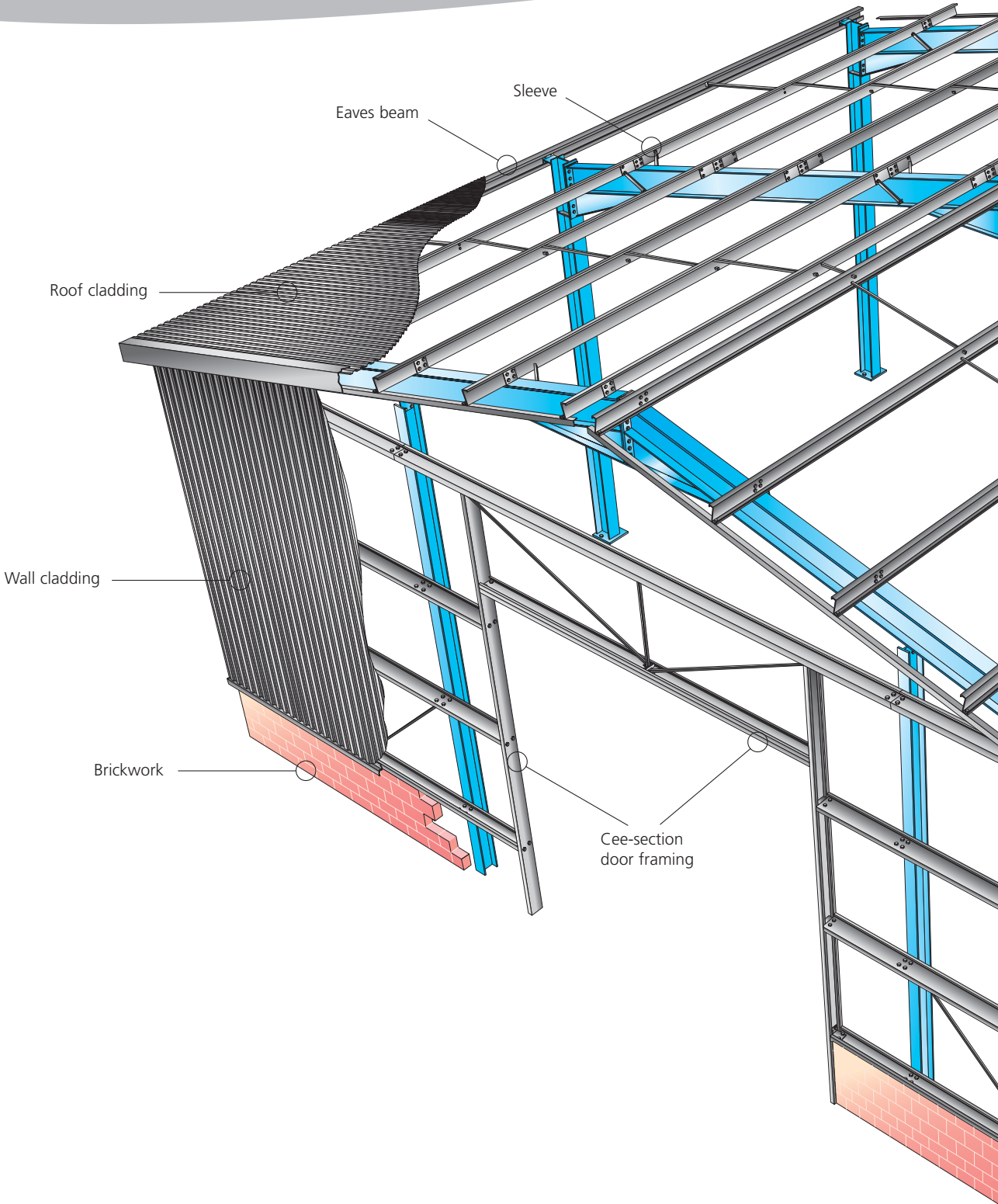

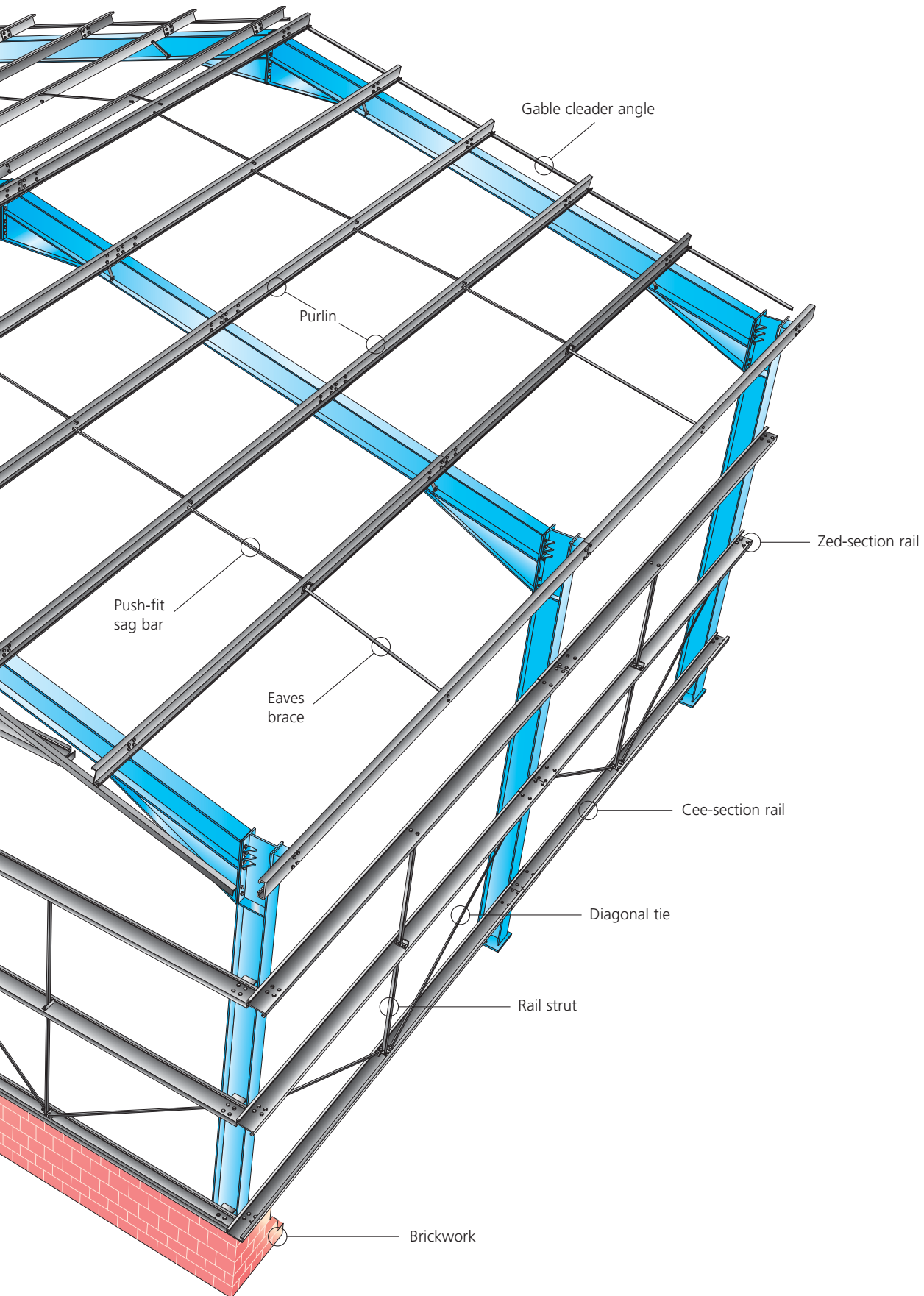

PURLINS, RAILS & EAVES BEAMS

ZED AND CEE SECTION RANGE

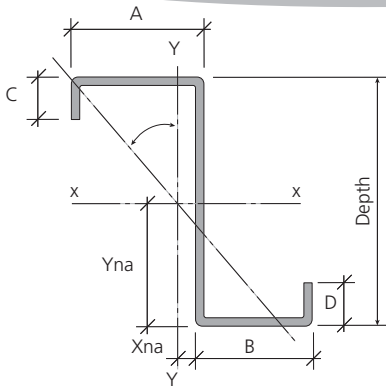

Table 01: Zed & Cee profile dimensions

Section Depth	Zeds				Cees	
	A	B	C	D	E	F
140,170	60	54	16	20	62	13
200	70	64	16	20	70	15
240	75	67	18	22	74	17
300	95	87	21	25	95	19

Dimensions in mm

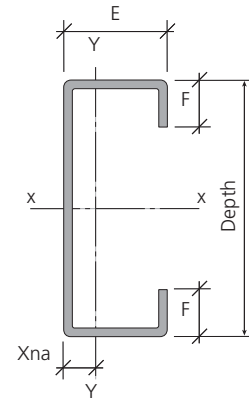

Table 02: Standard Zeds - 390N/mm² steel grade

Section	Wt (kg/m)	Area (cm ²)	Zxx (cm ³)	Zyy (cm ³)	Ixx (cm ⁴)	Iyy (cm ⁴)	Rx (mm)	Ry (mm)	Po (N/mm ²)	Qs	α	xna (mm)	yna (mm)	Mc (kNm)
14014	3.06	3.81	13.97	4.37	116.8	29.3	55.3	27.7	350.7	0.641	22.4	0.1	70.7	5.45
14015	3.26	4.08	15.49	4.79	124.7	31.2	55.3	27.6	356.8	0.667	22.4	0.0	70.7	6.04
14016	3.48	4.35	17.00	5.22	132.7	33.1	55.2	27.6	362.2	0.693	22.3	0.0	70.7	6.63
14018	3.90	4.89	19.87	6.04	148.4	36.8	55.1	27.4	371.1	0.731	22.2	-0.1	70.7	7.75
14020	4.32	5.43	22.44	6.83	164.0	40.4	55.0	27.3	378.2	0.762	22.2	-0.2	70.7	8.75
17014	3.38	4.22	17.44	4.18	184.0	29.4	66.0	26.4	331.4	0.582	17.3	0.0	85.8	6.80
17015	3.62	4.52	19.37	4.60	196.5	31.3	65.9	26.3	338.9	0.605	17.3	-0.1	85.8	7.55
17016	3.86	4.82	21.28	5.02	209.2	33.2	65.9	26.2	345.4	0.627	17.3	-0.1	85.8	8.30
17018	4.33	5.42	24.85	5.83	234.2	36.9	65.7	26.1	356.2	0.662	17.2	-0.2	85.8	9.69
17020	4.79	6.02	28.21	6.61	259.0	40.5	65.6	26.0	364.8	0.689	17.1	-0.3	85.8	11.00
17025	5.94	7.48	36.24	8.42	318.8	49.1	65.3	25.6	380.3	0.750	17.0	-0.6	85.8	14.14
20014	3.92	4.90	21.56	4.97	296.8	44.8	77.8	30.2	312.1	0.511	16.8	-0.1	100.7	8.41
20015	4.20	5.25	24.18	5.53	317.3	47.8	77.7	30.2	320.9	0.538	16.8	-0.1	100.7	9.43
20016	4.48	5.60	26.84	6.08	337.9	50.7	77.7	30.1	328.6	0.563	16.7	-0.2	100.7	10.47
20018	5.03	6.30	32.10	7.18	378.6	56.5	77.5	30.0	341.3	0.608	16.7	-0.3	100.7	12.52
20020	5.58	7.00	37.25	8.25	419.2	62.2	77.4	29.8	351.5	0.641	16.6	-0.4	100.7	14.53
20025	6.92	8.71	48.63	10.72	517.3	75.7	77.1	29.5	369.6	0.700	16.5	-0.6	100.7	18.97
24015	4.81	6.01	30.11	5.90	510.4	58.6	92.1	31.2	296.9	0.485	14.3	0.3	121.3	11.74
24016	5.13	6.41	33.61	6.54	543.7	62.3	92.1	31.2	306.2	0.509	14.3	0.2	121.3	13.11
24018	5.77	7.22	40.62	7.80	609.9	69.5	91.9	31.0	321.4	0.550	14.2	0.1	121.3	15.84
24020	6.39	8.02	47.36	9.04	675.8	76.5	91.8	30.9	333.6	0.583	14.2	0.0	121.3	18.47
24025	7.94	9.99	62.69	11.94	835.7	93.3	91.5	30.6	355.4	0.639	14.1	-0.2	121.3	24.45
24030	9.47	11.94	77.42	14.62	990.7	109.1	91.1	30.2	369.8	0.685	14.0	-0.5	121.3	30.19
30020	8.02	10.09	66.20	12.92	1344.7	157.4	115.4	39.5	306.8	0.503	14.5	0.0	151.3	25.82
30025	10.02	12.60	93.55	17.86	1668.1	193.1	115.1	39.2	334.1	0.581	14.4	-0.2	151.3	36.49
30030	11.97	15.08	118.11	22.48	1983.6	227.1	114.7	38.8	352.1	0.630	14.3	-0.5	151.3	46.06

Table 03: Standard Cees - 390N/mm² steel grade

Section	Wt (kg/m)	Area (cm ²)	Zxx (cm ³)	Zyy (cm ³)	Ixx (cm ⁴)	Iyy (cm ⁴)	Rx (mm)	Ry (mm)	Po (N/mm ²)	Qs	xna (mm)	yna (mm)	Mc (kNm)
14014	3.06	3.81	13.90	3.91	119.3	19.2	55.9	22.4	350.7	0.665	18.9	70.0	5.42
14015	3.26	4.08	15.44	4.26	127.4	20.4	55.8	22.4	356.8	0.699	18.9	70.0	6.02
14016	3.48	4.35	16.99	4.61	135.5	21.7	55.8	22.2	362.2	0.729	18.9	70.0	6.63
14018	3.90	4.89	20.00	5.29	151.5	24.1	55.7	22.2	371.1	0.779	18.9	70.0	7.80
14020	4.32	5.43	22.87	5.95	167.5	26.5	55.5	22.1	378.2	0.817	18.9	70.0	8.92
17014	3.38	4.22	17.34	3.79	187.1	20.4	66.6	22.0	331.4	0.604	17.1	85.0	6.76
17015	3.62	4.52	19.29	4.15	199.9	21.7	66.5	21.9	338.9	0.635	17.1	85.0	7.52
17016	3.86	4.82	21.25	4.51	212.7	23.1	66.4	21.9	345.4	0.660	17.1	85.0	8.29
17018	4.33	5.42	25.04	5.20	238.1	25.7	66.3	21.8	356.2	0.704	17.1	85.0	9.76
17020	4.79	6.02	28.69	5.88	263.4	28.3	66.2	21.7	364.8	0.740	17.2	85.0	11.19
17025	5.94	7.48	37.13	7.47	324.1	34.3	65.8	21.4	380.3	0.817	17.2	85.0	14.48
20014	3.92	4.90	21.57	4.62	299.2	30.3	78.1	24.9	312.1	0.540	19.0	100.0	8.41
20015	4.20	5.25	24.19	5.09	319.8	32.3	78.0	24.8	320.9	0.569	19.0	100.0	9.43
20016	4.48	5.60	26.85	5.57	340.6	34.3	78.0	24.8	328.6	0.598	19.0	100.0	10.47
20018	5.03	6.30	32.12	6.51	381.7	38.3	77.8	24.7	341.3	0.646	19.0	100.0	12.53
20020	5.58	7.00	37.27	7.42	422.6	42.2	77.7	24.6	351.5	0.684	19.0	100.0	14.54
20025	6.92	8.71	49.23	9.57	521.5	51.5	77.4	24.3	369.6	0.757	19.1	100.0	19.20
24015	4.81	6.01	30.15	5.53	514.0	40.8	92.5	26.1	296.9	0.512	19.0	120.0	11.76
24016	5.13	6.41	33.64	6.09	547.6	43.4	92.4	26.0	306.2	0.539	19.1	120.0	13.12
24018	5.77	7.22	40.60	7.19	614.1	48.5	92.3	25.9	321.4	0.586	19.1	120.0	15.83
24020	6.39	8.02	47.46	8.27	680.5	53.4	92.1	25.8	333.6	0.623	19.1	120.0	18.51
24025	7.94	9.99	63.62	10.83	841.5	65.3	91.8	25.6	355.4	0.690	19.1	120.0	24.81
24030	9.47	11.94	78.78	13.23	997.6	76.5	91.4	25.3	369.8	0.747	19.2	120.0	30.72
30020	8.02	10.09	66.02	11.90	1353.6	109.8	115.8	33.0	306.8	0.534	24.1	150.0	25.75
30025	10.02	12.60	93.33	16.16	1679.1	134.9	115.4	32.7	334.1	0.621	24.1	150.0	36.40
30030	11.97	15.08	119.18	20.19	1996.6	158.9	115.1	32.5	352.1	0.678	24.1	150.0	46.48

ZED PURLIN SYSTEMS

Four structural systems are available, the Sleeved System, Double-Span Sleeved System, Heavy End-Bay System and the Butted System. These systems allow for a flexible and efficient range of solutions to roofing supports for a wide variety of cladding types, the major features of which are outlined below.

SLEEVED SINGLE SPAN SYSTEM

This is the traditional system of single bay-length sections with sleeves at all penultimate supports and at alternative internal supports. The system may be used with all types of claddings and roof pitches, within the limitations given in this manual. **Minimum number of spans is 2 and the maximum span is 12.5m.** Details are on page 32.

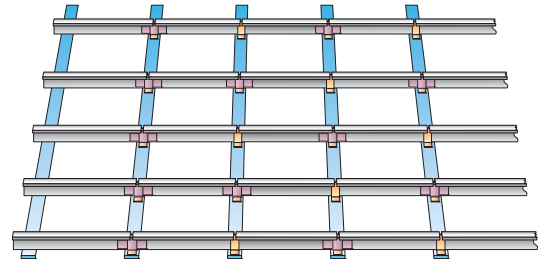

SLEEVED DOUBLE SPAN SYSTEM

Sleeves are provided at all penultimate supports and are staggered at internal bays. The advantage is a reduced number of erection components when compared with the Sleeved System. Note that maximum section length is restricted to 15m for transport and handling reasons. Consideration should be given to handling and erection sequence when utilising the double-span sections. **Minimum number of spans is 4 and the maximum span is 7.5m.** Details are on page 32.

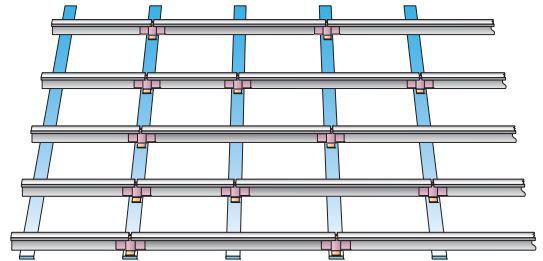

HEAVY END-BAY SINGLE SPAN SYSTEM

This is a highly efficient sleeved-system, with sleeves at all supports thus allowing a form of continuous beam design. Inner bay sections and sleeves are thinner than at the end bay thus allowing an economic solution for long buildings. Sleeves at penultimate supports are of the same thickness as the outer bay purlin section. **Minimum number of spans is 4 and maximum span is 12.5m.** Details are on page 32.

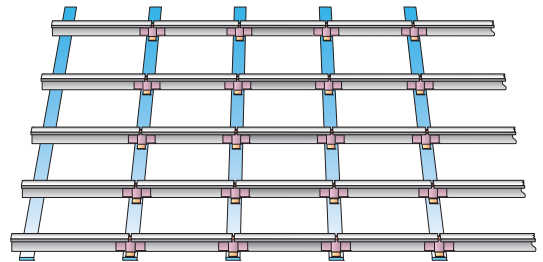

HEAVY END-BAY DOUBLE SPAN SYSTEM

Sleeves are provided at all penultimate supports and are staggered at internal bays. The advantage is a reduced number of erection components. Inner bay sections and sleeves are thinner than at the end bay thus allowing an economic solution for long buildings. Sleeves at penultimate supports are of the same thickness as the outer bay purlin section. **Minimum number of spans is 4 and maximum span is 12.5m.** Details are on page 32.

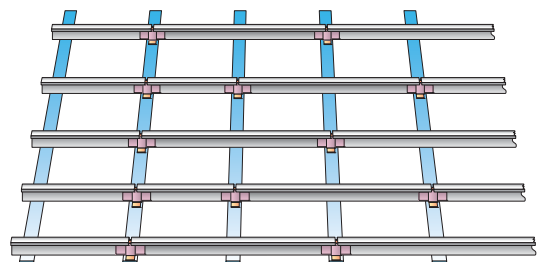

PURLINS, RAILS & EAVES BEAMS

ZED PURLIN SYSTEMS

SLEEVED PURLIN SYSTEM

Single/double span lengths

Refer to pages 04 - 05 for overview of system and sleeve requirements. This system may be used with restraining or non-restraining cladding, and may also be used to support tiled roof systems. The system may require to be used in conjunction with sag-systems as identified for various conditions on page 09. Consideration should be given to handling and erection sequence when utilising the double-span section.

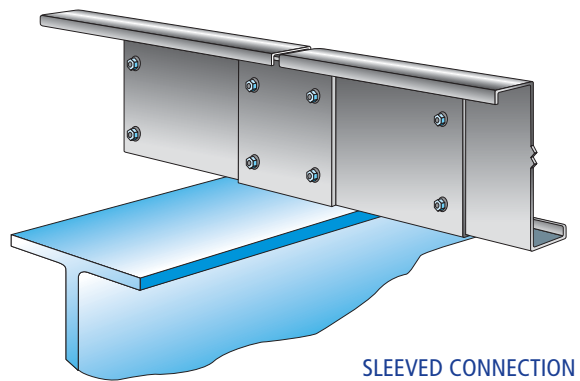
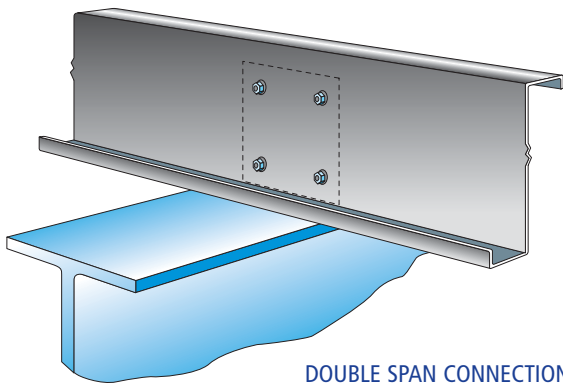

BUTTED SINGLE SPAN SYSTEM

The system is required for buildings of a single span length and is efficient for short spans or light loadings. Butted purlins are also useful for frames which have large clear spans and where large frame deflections may be harmful to continuous purlin systems. Butted purlins can be used over supports or within the depth of the supporting section.

Maximum span is 11.4m. Details are on page 32.

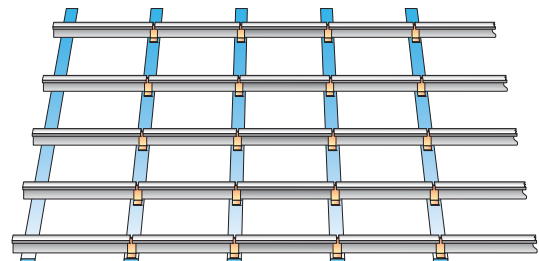

BUTTED PURLIN SYSTEM

This system is useful for single-span conditions, either over-supports or flush with supports. The system is also economical for small bays or light loadings, where sleeves are not necessary.

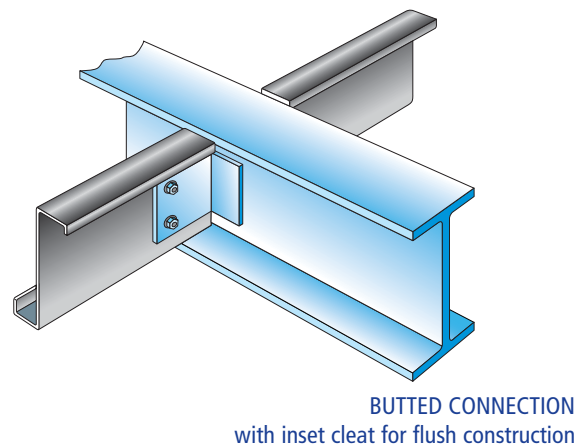
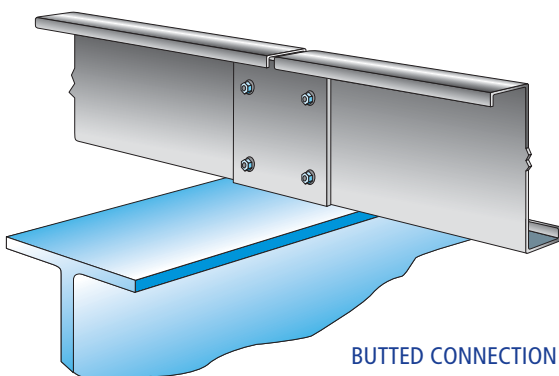

ROOF SAG-SYSTEM REQUIREMENTS

The anti-sag-system required for any given case will depend on the loadings, span, cladding type and roof pitch. Different claddings provide varying restraint to the purlin and it is extremely important that the roof designer should be clear on the type of roof cladding prior to selecting a suitable sag system. For purlin design purposes within the scope of this manual the following list outlines the main cladding types to be considered:

- 1) Restraining type metal cladding
- 2) Non-restraining type metal cladding
- 3) Hook bolt fixed cladding
- 4) Tiled roofs

Lateral restraint is usually provided to the purlin where normal trapezoidal, or composite cladding is through-fixed to the purlins and where the sheets are fixed together by side lap stitching. Standing seam roofs and some forms of secret fix panels have fixings which allow relative movement between the purlin and the cladding and these panels should be regarded as non-restraining unless used in conjunction with a suitable liner panel. A suitable liner panel should be sufficiently robust to carry compressive restraint forces and should be positively fixed to the purlin and it is also recommended that side lap stitching is adopted to form a roof plane diaphragm.

Some claddings, such as fibre cement panels, are fixed by hook bolts. These claddings offer a reduced degree of restraint to the purlin under wind uplift conditions and the limitations given in this section should be observed for this application. Wind uplift capacities are reduced, and sections for these roofs should be selected using the design disk.

See the Tiled Roof section for additional sag system requirements for tiled roofs.

Sag system recommendations for various roof conditions are provided in the table right and these should be used as appropriate. Use of the sag systems indicated will provide optimum wind uplift capacity and will provide a good basis for stability and alignment during erection.

In the case of restraining type metal cladding a reduced number of rows of sag bars may be appropriate in particular circumstances. It should be clear that these reduced systems should only be used in conjunction with the appropriate load tables which, depending on span, may have significantly reduced wind uplift values. The following points should be considered for reduced numbers of sag bars:

1. Reduced number of sag member rows applies only to restrained type metal cladding.
2. For roof slopes less than 3°, 0-rows may be used for spans up to 4.6m and 1 row of angle braces may be used for spans up to 12.5m.
3. For roof slopes between 3° - 25°, 0-rows may be used for spans up to 7.6m and 1-row of push fit sag bars may be used for spans up to 12.5m.
4. Use the reduced wind uplift capacity relevant to the number of rows of sag members selected.
5. Temporary stability during erection, and other Health & Safety issues should be considered when choosing a suitable sag system.
6. When 0 rows of sag members are used it is recommended that one row of eaves braces and ridge struts be used.

Table 04

Cladding System	Slope Roof	Roof Sag System Details		
		< 4.6m span	4.6m - 7.6m span	7.6m - 12.5m span
Metal Cladding (restraining type)	< 3°	1 row angle braces		2 rows angle braces
	3° - 25°	0 rows	1 row bars	2 row bars
	25° - 35°	1 row angle braces + diagonals		2 rows angle braces + diagonals
Metal Cladding (non-restraining type)	<3° 3° - 25°	1 row angle braces		2 rows angle braces
	25° - 35°	row angle braces + diagonals		2 rows angle braces + diagonals
Hook-bolt (restraining type)	< 3°	Not recommended		
	3° - 25°	1 row bars		2 row bars
	25° - 35°	1 row angle braces + diagonals		2 rows angle braces + diagonals

PURLINS, RAILS & EAVES BEAMS

ZED PURLIN SYSTEMS

ROOF SAG BAR SYSTEM

Useful for restraining metal cladding and hook bolt cladding within the limit of the table. Suitable for purlins up to 240mm deep.

Push-fit sag bars are used up to 2.0m purlin centres. Refer to Steadmans if centres are greater than 2m.

(Refer to table on page 09 for limitations of use.)

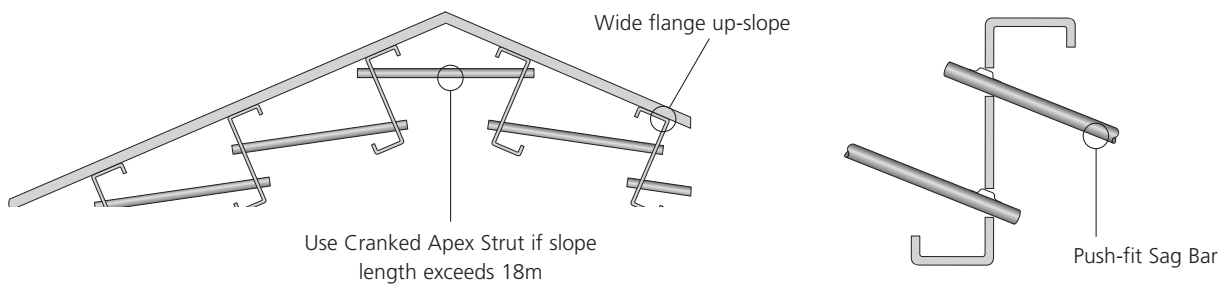

ROOF ANGLE BRACE SYSTEM

Useful for non-restraining cladding, tiled roofs and for purlins 300mm deep and steep roofs (ie. over 25°)

45 x 45 x 2 angle braces may be used up to 2.0m purlin centres. Refer to Steadmans if centres are greater than 2m.

(Refer to table on page 09 for limitations of use.)

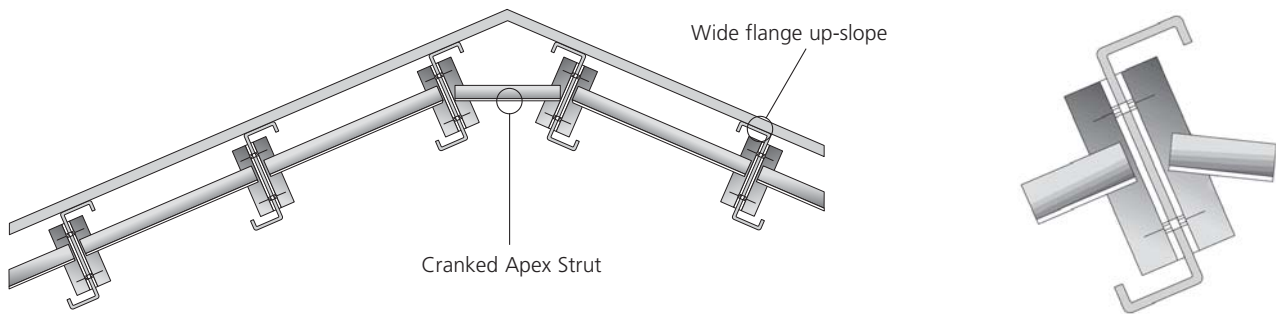

General Notes:

Note that where sag bar numbers are reduced, within the limits of this manual, it may be necessary to use temporary bracing to the top flange to avoid twisting of zed purlins during installation, particularly on roofs with shallow or steep slopes. In the case of 0 - rows of sag bars it is recommended that eaves braces are fitted (see Eaves Beam section of manual - page 16) and that a ridge bar or cranked apex strut is fitted, as in above details.

Where sag bars or angle braces are used they should be positioned at mid-span for a single row and at $\frac{3}{8}$, $\frac{1}{4}$, $\frac{3}{8}$ span for a double row, for optimum resistance to wind uplift.

Refer to the Eaves Beam section of the manual (page 16) for general recommendations for sag systems at eaves.

Refer to the Tiled Roof section (page 14) for advice on dealing with such heavy roofing systems.

MONOPITCH ROOFS

In a monopitch roof all the roof plane forces act up or down the roof unlike a ridged roof which has balancing roof load components acting through the ridge cladding and sag system. In the case of monopitches all roof-plane loads have to be resisted by the purlins, claddings, cleats and sag systems. However, with zed purlins the restraint forces which develop due to gravity loadings act in an up-slope direction, i.e. in opposition to the down-slope load component so that the roof system need only resist the net effect of these loads. (Note that a ridged roof which is not connected at the ridge should be considered as two monopitches.)

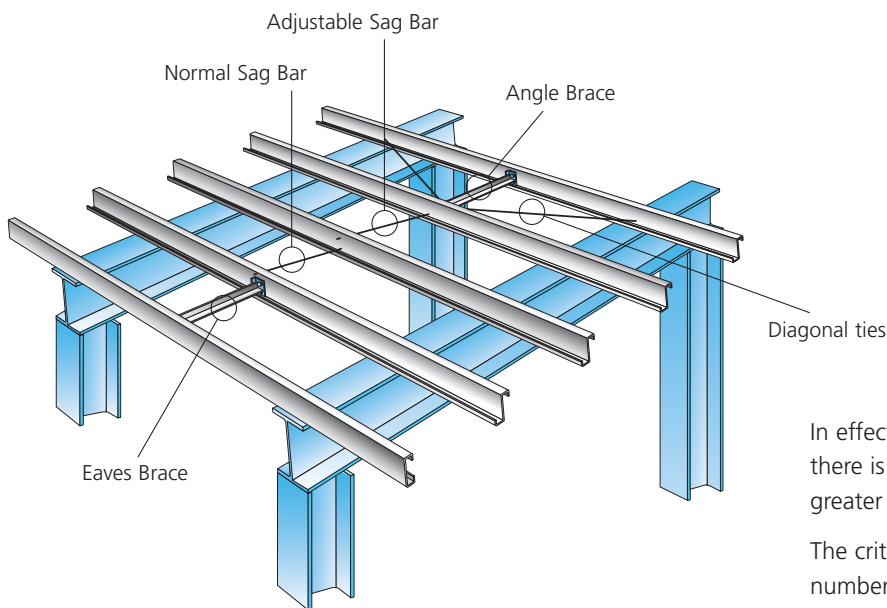
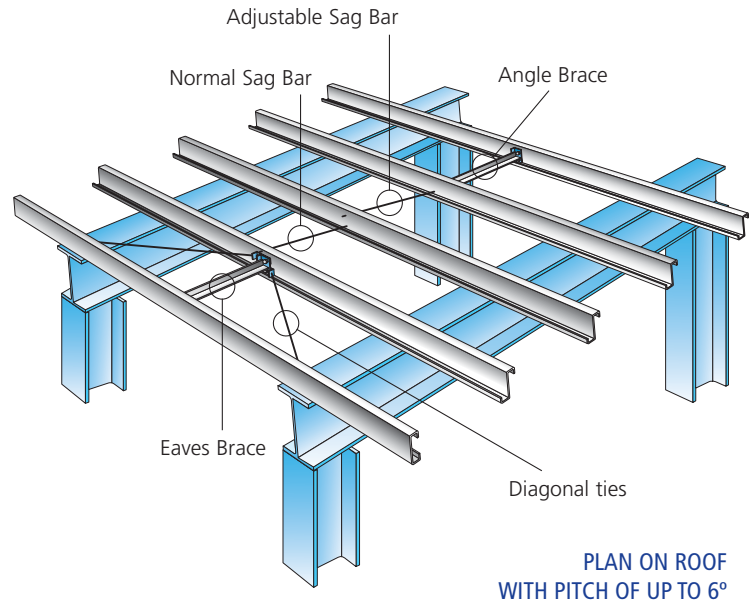

In effect, with roof pitches less than a critical value there is a net force acting up the slope and for greater roof slopes the force will act downslope.

The critical angle of roof pitch depends on a number of factors and can only be approximated with current knowledge. As an aid to designers it is recommended that diagonal ties and struts should be used to assist with load distribution in these roofs. The adjacent diagrams indicate the recommended placement of such elements for roof pitches less or greater than 6°, at which pitch roof forces are assumed to be approximately in balance.

Note: Anti-Sag bars (number of rows and type) to be taken from the table on page 09.

PURLINS, RAILS & EAVES BEAMS

ZED PURLIN SYSTEMS

STEEP PITCH ROOFS

Where roof slopes are greater than 25° but no greater than 35° the following points should be considered:

1. Use angle braces and cranked apex struts to replace normal sag bars. (Minimum number of rows provided on page 09).
2. Use diagonal ties at intervals of no more than 12m on the slope length, to assist with absorption of roof plane forces.
3. Reduce purlin capacity by including down-slope load component. This is most simply achieved by using the design program which automatically includes down-slope components for pitches greater than 25°.
4. Check purlin cleats for down-slope load component, use heavy duty cleats if required.

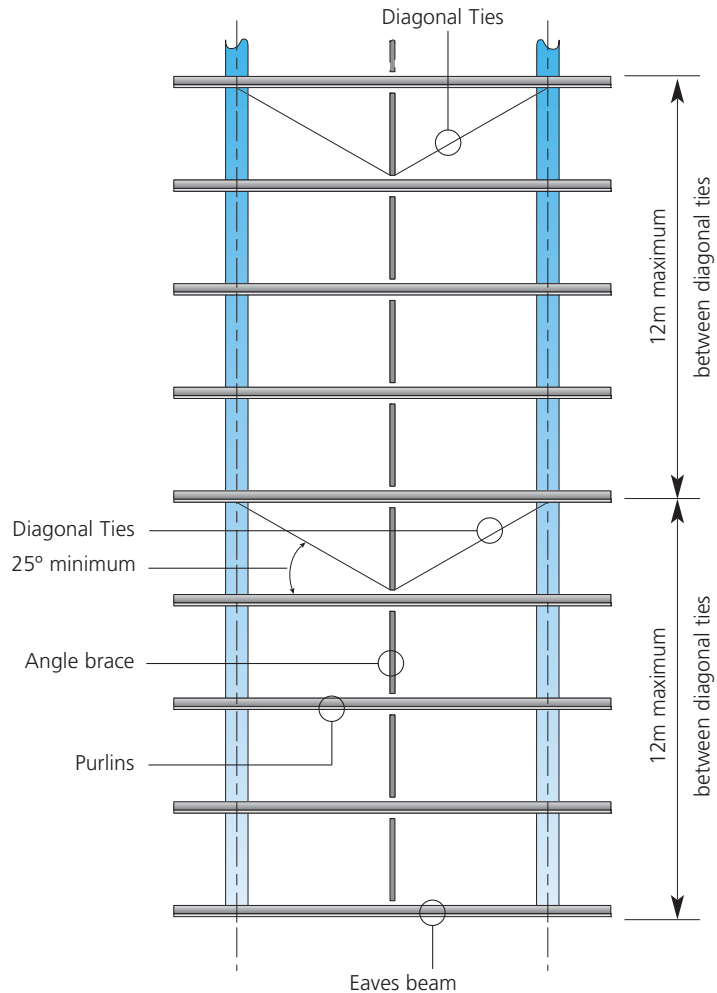

PLAN ON STEEP ROOF

SHALLOW PITCH ROOFS

For very flat roofs, say below 3° , particularly if the span exceeds 6m or if non restraining cladding is used then, in addition to the sag systems indicated in this manual the use of purlin reversals is highly recommended to balance the extensive up-slope restraint forces which develop due to the zed shape. This is particularly important in the case of any long slopes or monopitches and there should be slightly more zeds pointing up the slope than down slope.

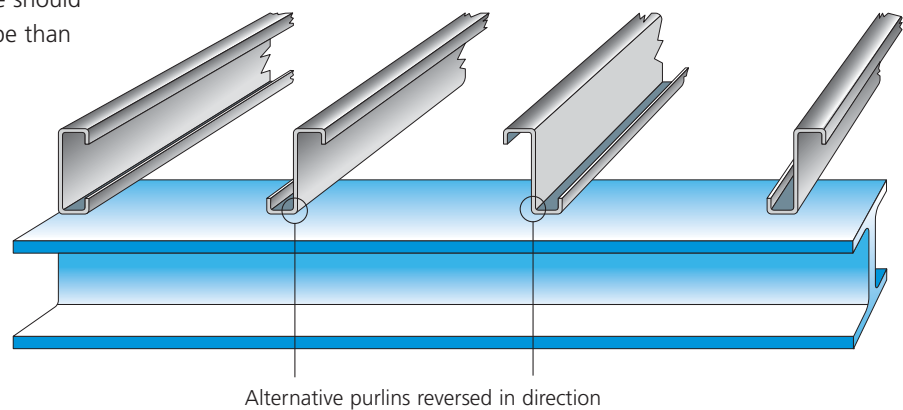

LONG ROOF SLOPES

For roof slopes in excess of 20m in length (on the slope), and with a pitch of greater than 3° it is recommended that each sub-length is divided into 20m (maximum) length sections and that each section is stiffened in the roof plane by the addition of angle struts and diagonal ties, as indicated. For long roofs with a pitch below 3° a similar system should be adopted but the diagonal ties should be acting in the opposite direction.

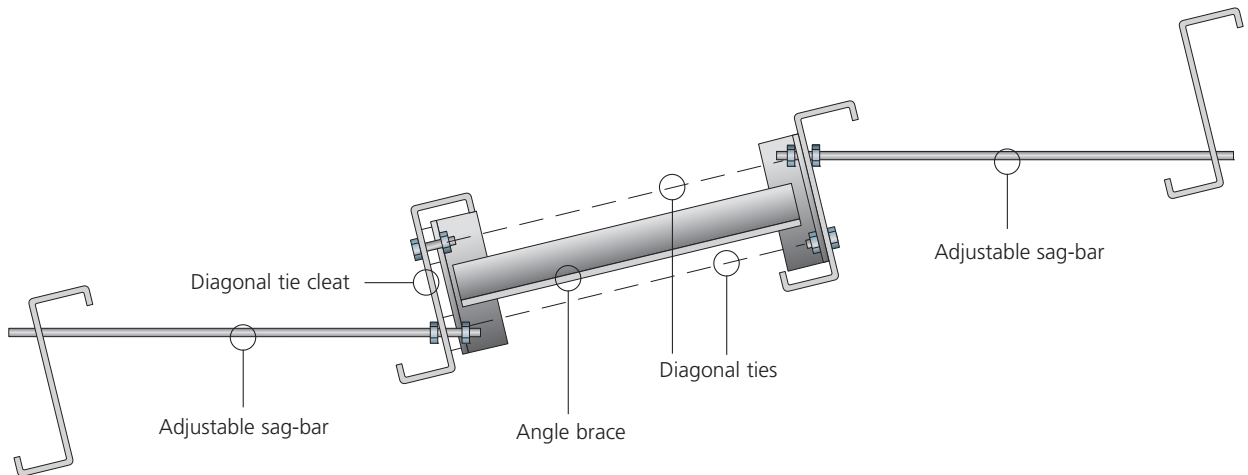

CURVED ROOFS

Curved roofs become flat near the apex and it is recommended that in the near-ridge zone, when the tangent to the roof cladding is less than 3°, then purlin reversals should be adopted as in the diagram. (ie The near-ridge zone is treated as a shallow pitch roof.)

Note: Anti-sag bars (number of rows and type) to be taken from the table on page 09.

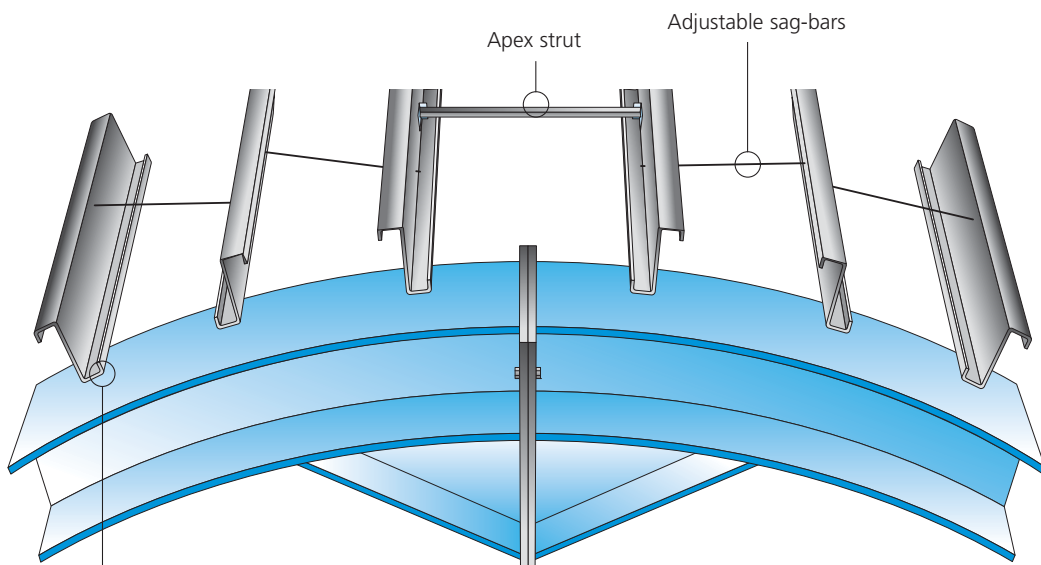

Alternative purlin directions reversed when roof tangent is less than 3°

PURLINS, RAILS & EAVES BEAMS

ZED PURLIN SYSTEMS

TILED ROOFS

Cold rolled purlins are increasingly being used to support tiled roofs. This application is particularly suitable for Zeds which have principal axes inclined from the web axes and which consequently have upslope restraint forces acting in opposition to the downslope load component thus minimising the large downslope forces inherent to this form of roofing.

Two types of application are common for use with natural slate or concrete tile materials:

1. Tiles may be fitted to timber battens nailed to counter battens which are screw fixed to the top flange of the purlins.
2. Tiles may be fitted to timber battens fixed to a proprietary metal liner tray.

Some special considerations are required when designing a tiled roof:

1. Purlins should be limited to a deflection of span/300 in the web plane to avoid visible sag.
2. Where a building is ridged, when timber counter battens are used they should be bolted together at the ridge to balance the down-slope forces so far as is possible.
3. Any timber counter battens fixed up the slope of the roof should be attached to each other with metal straps to assist in carrying the tensile forces which will develop in the roof.
4. The Sag-System must be sufficiently robust to handle the down-slope load component, and the purlins require to be designed for two-way bending, as in the steep roof section above. Use angle braces at sag member positions, in conjunction with diagonal ties. If loadings are substantial the diagonal ties should be fixed directly to the steel supporting rafter.
5. Cleats should be checked for their ability to handle the large down-slope forces, use heavy duty cleats if necessary.

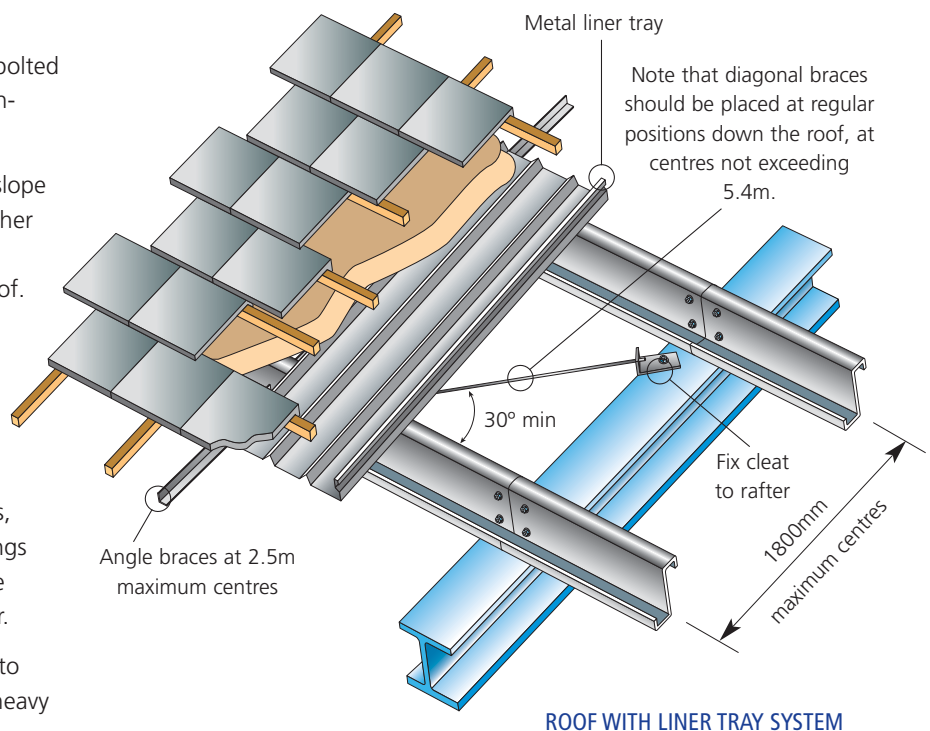
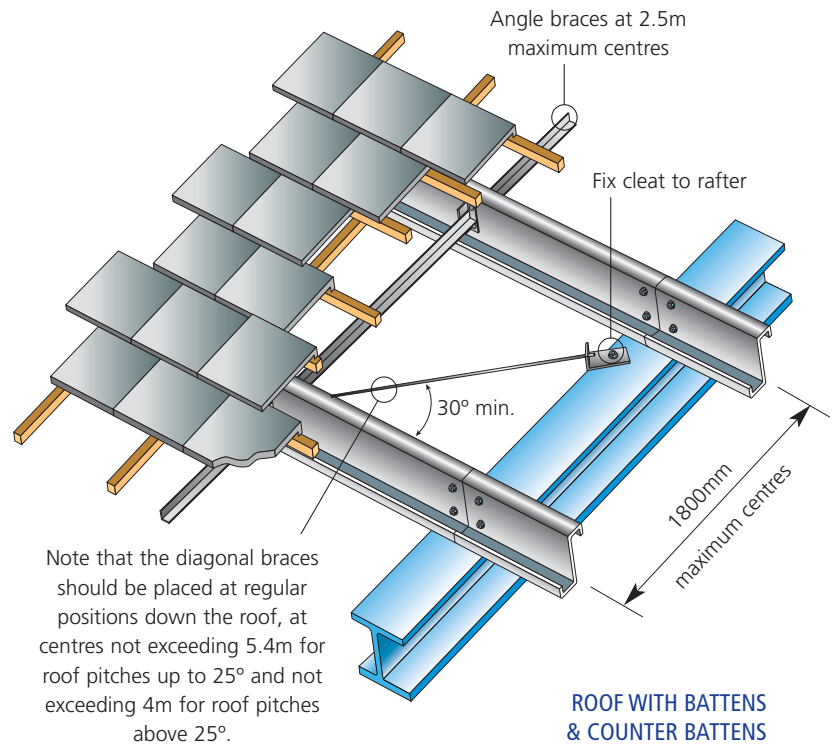

TILED ROOFS

No load tables are provided for this application and assistance in particular situations can be obtained by discussing the requirements with Steadmans, or the design program can be used if the roof pitch exceeds 25°.

Some typical details are provided, for the purpose of general guidance in the design of these roofs.

Note that in addition to the use of natural materials Steadmans offer the unique Meta-Slate roof system which combines the natural look of slate with the lightweight construction of pressed steel construction (see separate technical brochure). Purlins for this application should be designed as for non-restraining metal cladding.

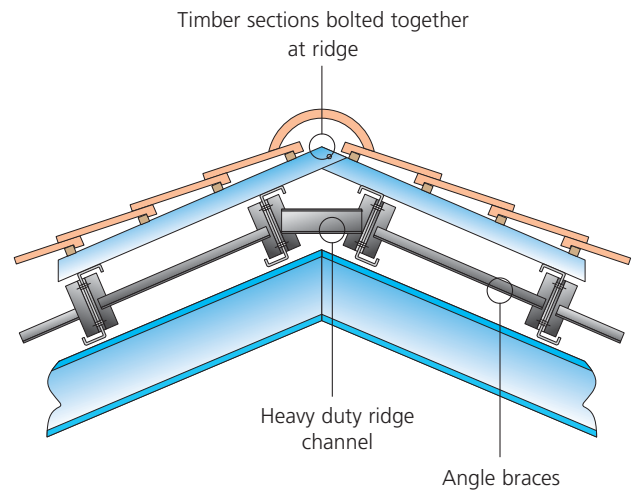

CANTILEVER PURLINS

These are frequently required to form gable overhangs, with or without deep soffit framing. Performance depends on the purlin section and on the backing span. The purlin section should be no less than that required for the adjacent main span, selected in the absence of the cantilever loading. Where deflections are critical the purlin section should be chosen accordingly, following the guidance below. Purlin sections should be confirmed by evaluation, considering the following parameters:

1. Purlin section must be continuous over the gable frame.
2. Maximum cantilever span is 30% of the backing span, but not greater than 3m.
3. Bottom flange should be restrained by cladding or by restraints at centres not exceeding the lesser of 2m and ten times the section depth.
4. Purlin ends should be braced with cleader angles top & bottom or with an angle brace providing torsional restraint, placed near the end. Restraint should be carried across the ridge where applicable.
5. The factored BM at the support should not exceed the purlin moment capacity for gravity or wind uplift effects (M_c in the section property table).
6. Tip deflection should be limited by increasing the purlin section, if required.
7. Where the cantilever span exceeds 1.0m a diagonal tie should be fitted as in the sketch. This is particularly important in the case of steep roofs, monopitches and heavy claddings.
8. Special care is required with heavy roof claddings or tiled roof systems. Refer to Steadmans for advice in particular cases.

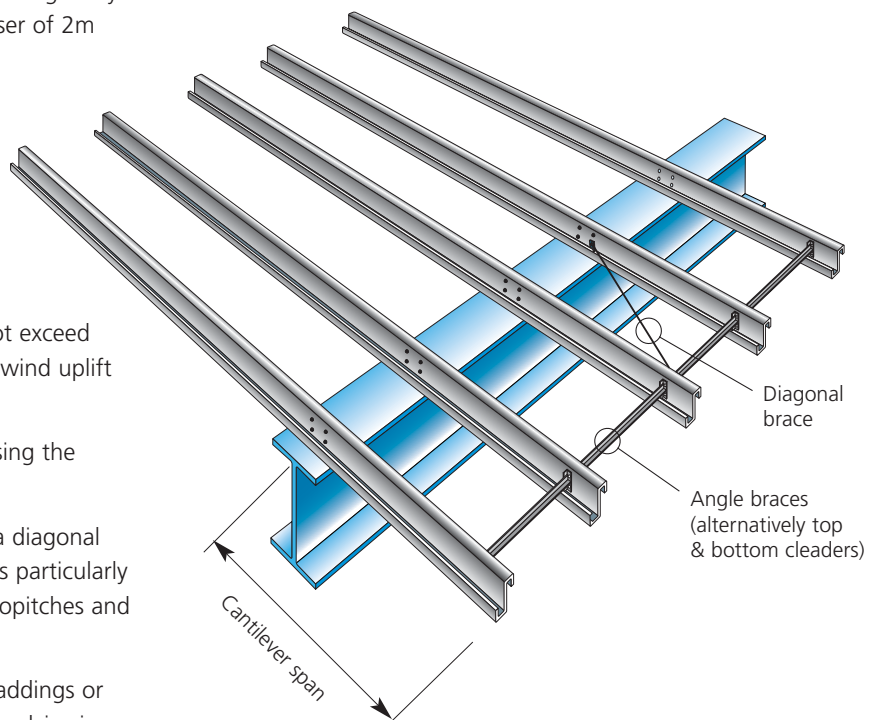

PURLINS, RAILS & EAVES BEAMS

EAVES BEAMS

SECTIONS

Three depths of eaves beam are available. Folded indented sections with a maximum length of 10m are available in 200mm and 240mm depth. A 300mm deep Cee section eaves beam is available up to a span of 12.5m to complement the 300 series of purlin sections. These are available in the thicknesses indicated. Eaves beams are usually single spanning but the 200 and 240 series may be supplied as double-spanning up to a 5m span and the 300 series can be double-spanning up to a 7.5m span.

The 300mm deep eaves beams may be optionally used with counterformed holes and countersunk bolts, with either countersunk holes or spacer plates as indicated.

It is recommended that at least one row of eaves braces should be adopted, even where a zero row of sag bars is used with the purlins. Additionally the number of rows of eaves braces should not be less than the number of rows of sag bars for purlins, as in the table on page 09, or as selected by the designer to suit any particular design. Removal of eaves braces should only be carried out if the

roof designer is confident that the structural implications have been fully considered.

Eaves braces perform the following functions:

1. Reduce the horizontal design span for side wind.
2. Assist with dispersing horizontal wind loads into the roof diaphragm.
3. Reduce any twisting due to eaves gutters and with erection of roof cladding.

The eaves beam design tables and design disk are based on the assumption that the top flange is fully restrained by the roof cladding and care is required where this is not the case, for example where standing seam or clip-fixed cladding are used without a suitably stiff liner panel. Most design situations can be handled using the design disk but due to the many conditions that may be met in practise, section properties are provided to assist the designer with any individual designs that may be required.

200 EAVES BEAM SERIES

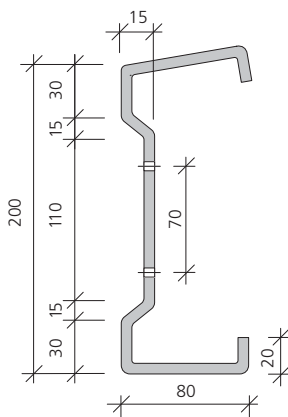

Rake to flanges available from 0° to 35° (above 35° contact Steadmans)

240 EAVES BEAM SERIES

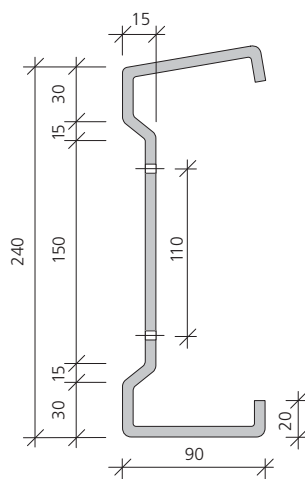

300 EAVES BEAM SERIES

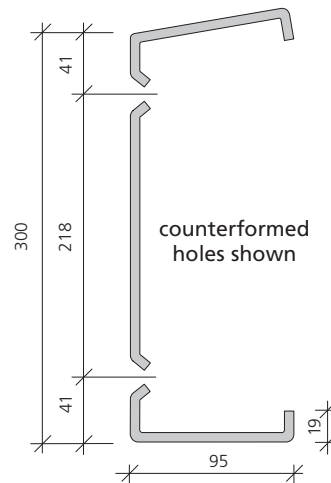
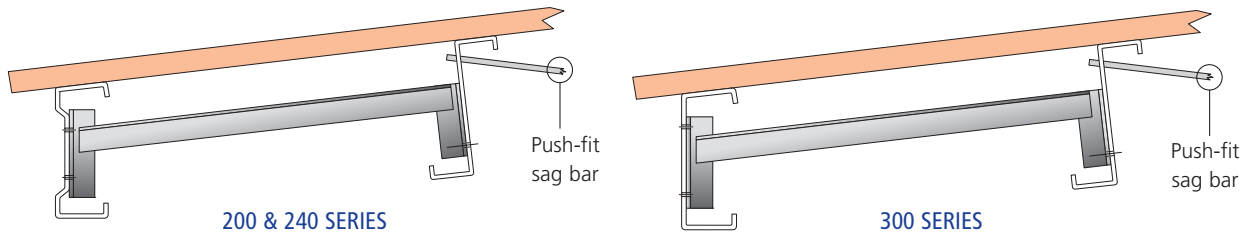

Table 05: Sections

Section	Weight (kg/m)	Sxe (cm ³)	Ixx (cm ⁴)	Zyy (cm ³)	Iyy (cm ⁴)	Ryy (mm)	Poc
EB200/16	5.10	35.48	373.8	8.66	44.9	26.3	350
EB200/20	6.35	47.68	487.7	10.64	55.1	26.1	350
EB200/25	7.90	61.70	620.3	13.02	67.3	25.9	350
EB240/25	9.08	83.09	1009.3	15.80	94.1	28.5	350
EB240/30	10.84	101.18	1218.0	18.58	110.6	28.3	350
EB300/30	11.97	134.59	2026.0	22.32	159.0	32.3	329

TYPICAL EAVES BEAM DETAILS

EAVES BRACES FOR ROOF SLOPE LENGTH UP TO 18M



EAVES BRACES FOR ROOF SLOPE LENGTH GREATER THAN 18M

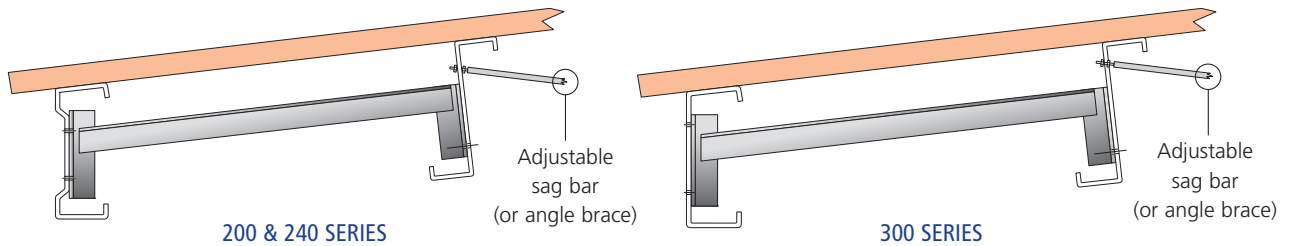

TYPICAL CONNECTIONS TO COLUMN HEADS

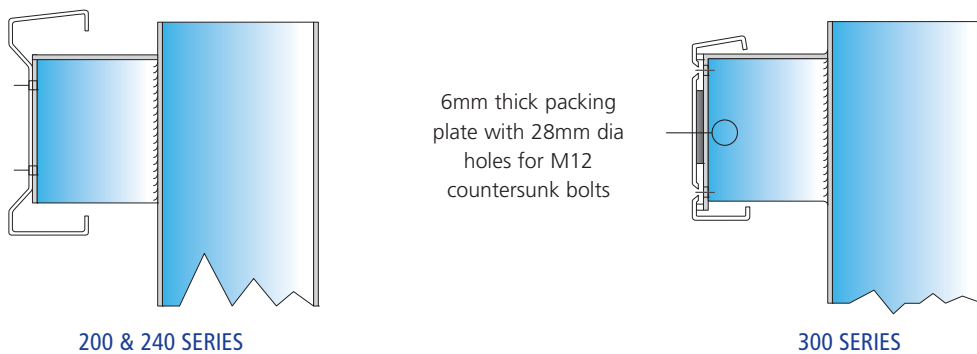

OUTSTAND CONNECTIONS

PURLINS, RAILS & EAVES BEAMS

EAVES BEAMS

TYPICAL CONNECTIONS TO COLUMN HEADS

FLUSH COLUMN CONNECTIONS

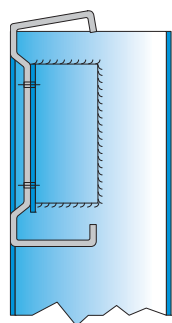

200 & 240 SERIES

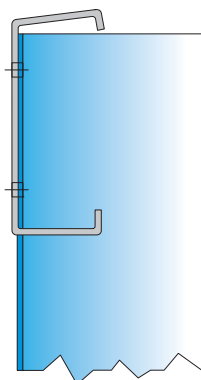

300 SERIES

CONNECTIONS BETWEEN EAVES BEAMS AND RAIL STRUTS

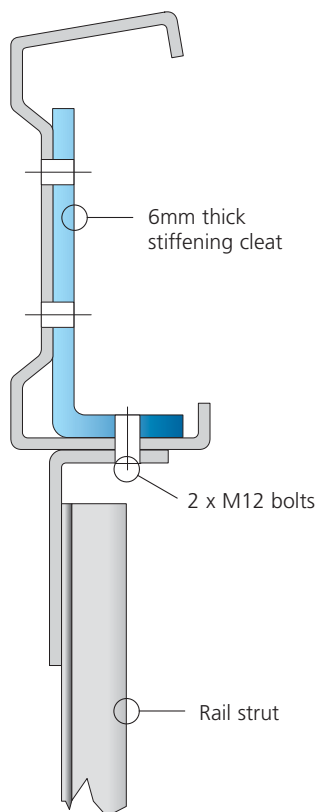

200 & 240 SERIES

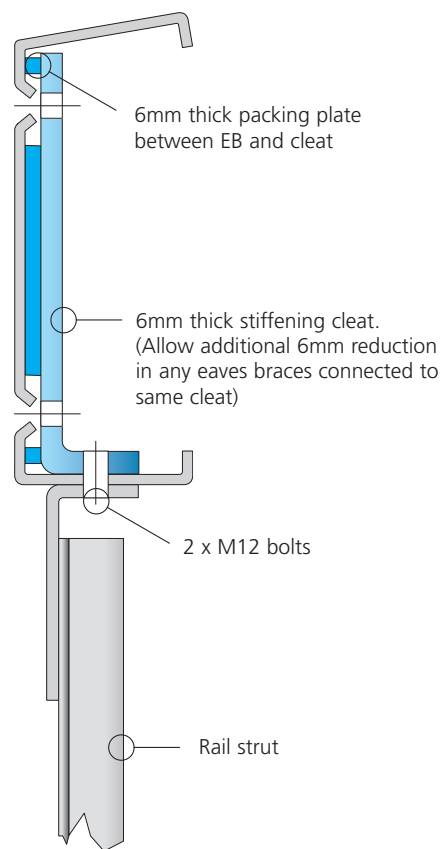

300 SERIES

ZED AND CEE SHEETING RAILS

Sheeting rails may be selected as either Zed profile or Cee profile sections. These are formed from the same coils and are each available in the same depth and thickness range. Cees may be substituted for Zeds at window and door framing and at composite cladding joints, etc.

The two types of section can be mixed on the same rail line though it is not possible to locate sleeves on the junction between Zeds and Cees. Each system should be regarded separately between such junctions when considering load capacities.

Three basic systems are given in this manual, i.e. the Sleeved System, the Butted System and the Double Span (Brick Restraint) System. A Heavy End-Bay System can be used though in practice this may be hampered by interaction with door standards, etc, and the designer will require to exercise caution if this system is used (and indeed may require to anticipate the possibilities of future alterations to the wall structure). The design disc provides a method of load assessment for this system.

SLEEVED SYSTEM

This is a system of single bay length sections with sleeves at penultimate supports and at alternative internal supports.

Minimum number of spans is 2 and the maximum span is 12.5 metres. Details are on page 32.

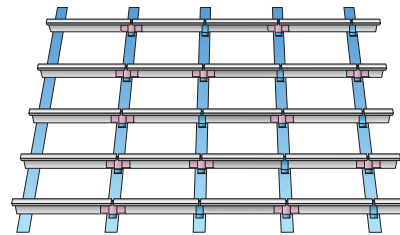

BUTTED SYSTEM

This is a single span system. The system is required for single bay length rails and is efficient for short spans or light wind loadings. Sections can be fitted running past the supports or may be within the depth of supporting sections. **Maximum span is 11.4 metres.** Details are on page 32.

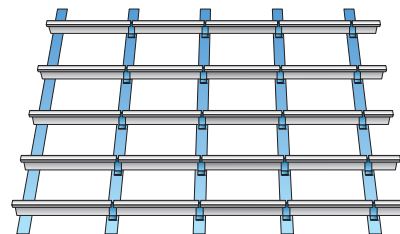

DOUBLE SPAN SYSTEM (BRICK RESTRAINT)

This is a relatively stiff system intended for use as brickwork restraints, or as window framing. **Minimum number of spans is 2 and maximum transport length of section is 15 metres thus maximum span is 7.5 metres.**

Use double-span sections for the full length if the wall has an even number of bays and use a triple-span rail, ie double-span plus a sleeve, if an odd number of bays. Section thickness may require to increase for the triple-span case to compensate for the reduced stiffness, when compared with the double span system.

Details are on page 32.

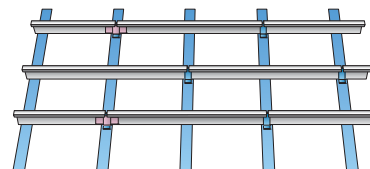

DESIGN DISK ALLOWS FOR VARIATION IN DEFLECTION FACTOR

PURLINS, RAILS & EAVES BEAMS

ZED AND CEE SHEETING RAILS

SLEEVED RAIL SYSTEM

Typical connections are illustrated for sleeved joints for both Zed and Cee Sections.

Note that the sleeves for the Zed System may be the same thickness as the rail section but sleeves for the Cee System are provided in one standard thickness for each rail depth.

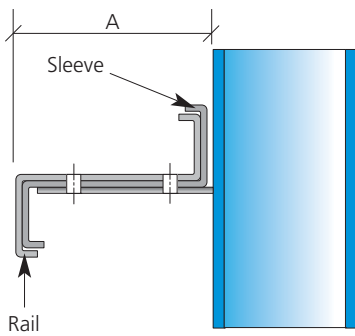
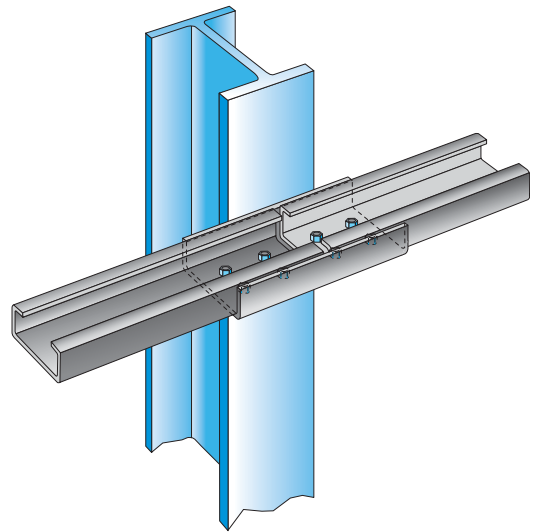
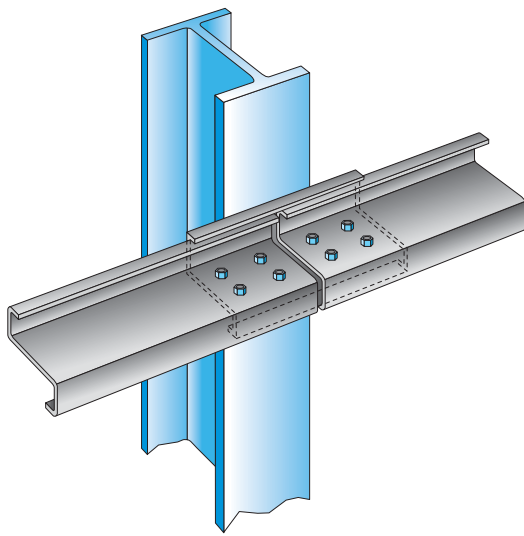

ZED RAILS

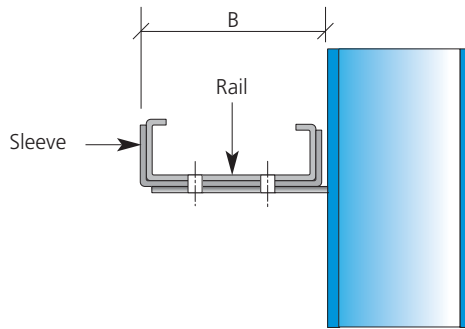

CEE RAILS

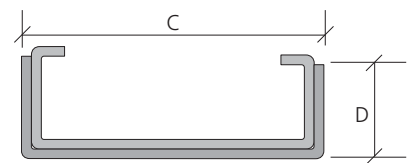

SECTION AT SLEEVED CEE SECTION RAIL

Table 06

Rail Depth	Dimension A	Dimension B	Dimension C	Dimension D	Thickness for Cee Sleeve
140	148	147	146	60	2.0
170	178	177	177	60	2.5
200	208	207	207	70	2.5
240	248	247	248	70	3.0
300	308	307	308	90	3.0

ZED RAIL FLANGE TO THE CLADDING MUST TOE UPHILL FOR FIBRE-CEMENT, HOOK BOLT FIXED

BUTTED & DOUBLE SPAN RAIL SYSTEM

The connections for these two systems are identical except that the Butted System has a butted connection at every frame and the double-span system has a butted joint at alternative connections and is continuous over intermediate supports.

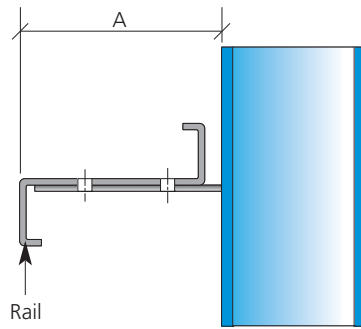

ZED RAILS

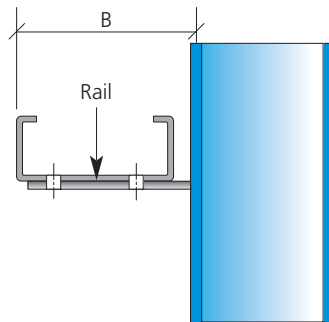
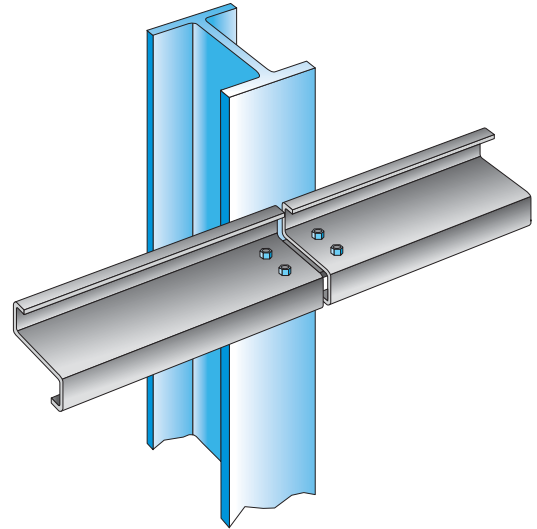

CEE RAILS

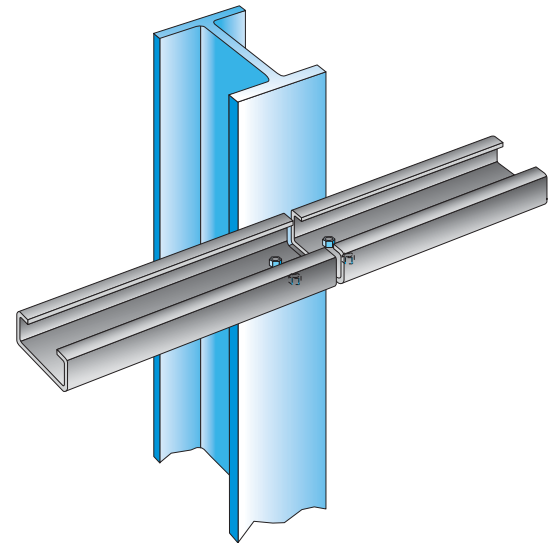

TYPICAL BRICK RESTRAINT DETAILS

Typical details are indicated for illustration. The brickwork designer is responsible for design of the blockwork to rail connections and should select rails on the basis of a suitable deflection limit.

A deflection limit of $\text{span}/300$ is commonly employed and the design program defaults to that limit for double span systems. The user may alter this as required.

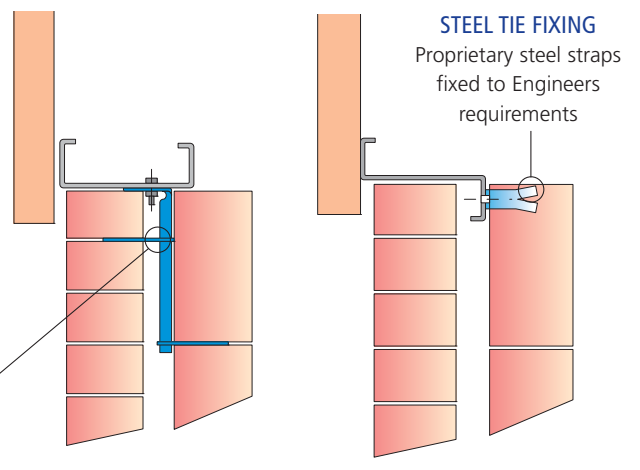

PURLINS, RAILS & EAVES BEAMS

ZED AND CEE SHEETING RAILS

SHEETING RAIL SAG-SYSTEM REQUIREMENTS

The user should note that it is assumed in the development of details and load tables that wall claddings will provide a diaphragm action and will be positively fixed to the rails, thereby eliminating vertical bending in the rails. Any claddings which do not meet these criteria should be referred to Steadmans, or the program may be used with the cladding weight included.

The number of rows of sags members for normal use is provided in the table, shown below for restraining-type metal cladding and fibre-cement cladding. The table also provides limiting dimensions for a number of cases.

Less limiting conditions can be applied for support of restraining type metal cladding, in certain cases. Where the cladding weight can be carried by floors, brick wall heads or eaves beams or by diaphragm action, and where the reduced wind load capacity is acceptable then 0 rows of sag bars may be adopted up to a 6.3m span, and a single row may be used up to a 7.6m span. In the case of 0 rows being adopted then temporary supports may be required to prevent sag in the rails during erection.

The usual system of rail restraints comprises the use of 45 x 45 x 2 angle section rail struts, with diagonal ties, as indicated on the next page.

Table 07: Limiting Dimensions for normal conditions

Cladding type	Case	Number of rows of sag members			
		0	1	2	3
Restraining type metal cladding	Maximum span for Normal Sag System	3.0m	6.3m	10.0m	12.5m
	Maximum panel height /set of diagonal braces	n/a	10.0m	10.0m	7.5m
Fibre-cement cladding	Maximum span	2.4m	5.1m	7.6m	10.0m
	Maximum panel height /set of diagonal braces	n/a	7.0m	7.0m	6.0m

Additional Notes:

1. In the case of multiple rows of rails the maximum number of rails per set of diagonals should be limited to 8.
2. For double-row sag systems in walls the sag members are placed at 1/3 spans for a uniform appearance. For triple row systems place sag members at 1/4 spans.
3. For spans in excess of 10m use heavy duty angular diagonal ties in place of tie wires.
4. Advice should be sought from Steadmans when supporting any special claddings, such as clip fixed, which offer less restraint and reduced diaphragm action.
5. Support cleats should be checked for their capacity to handle wall cladding weight where this exceeds 13kg/m² or where flat plate cleats are used. Similarly if wall glazing or other deflection sensitive claddings are used then the designer should confirm that the cleats have adequate bending resistance and consideration should be given to using heavy duty angular diagonal ties in such conditions.

SHEETING RAIL SAG SYSTEMS

* Note that for restraining type metal cladding up to 10m high the diagonal ties may be removed if the rail struts are taken up and securely fixed to the underside of the eaves beam, provided the eaves beam is designed to carry its tributary weight of wall panel. The fixing to the eaves beam should incorporate a stiffening cleat for wall heights greater than 4m, or with heavy claddings.

(See Eaves Beam section on page 16 for details.)

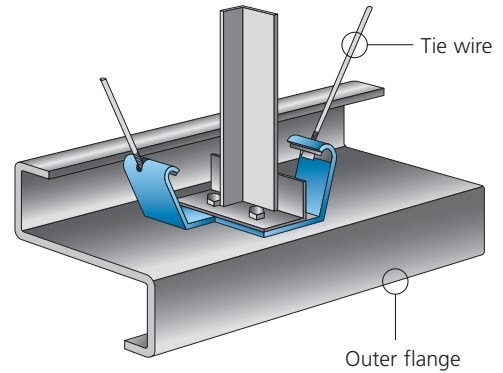

DIAGONAL TIE FIXING TO RAIL STRUT

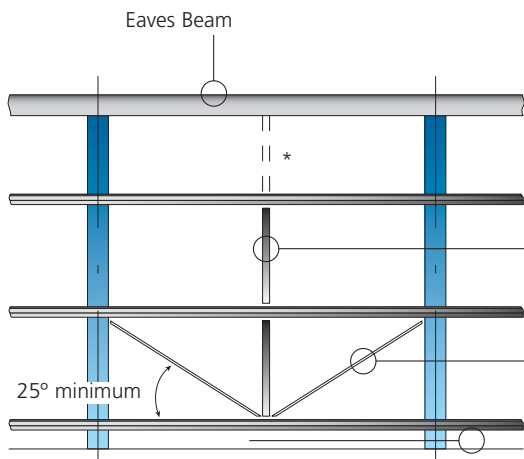

SINGLE ROW STRUT SYSTEM

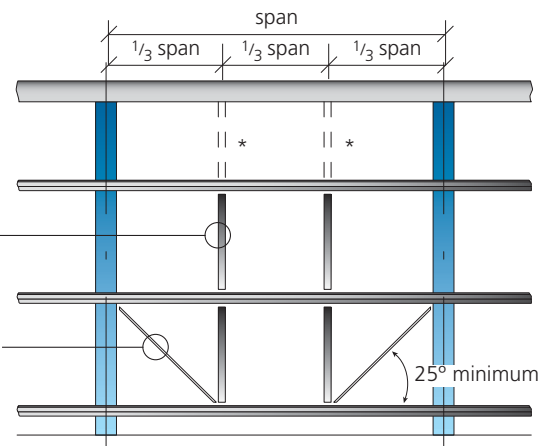

DOUBLE ROW STRUT SYSTEM

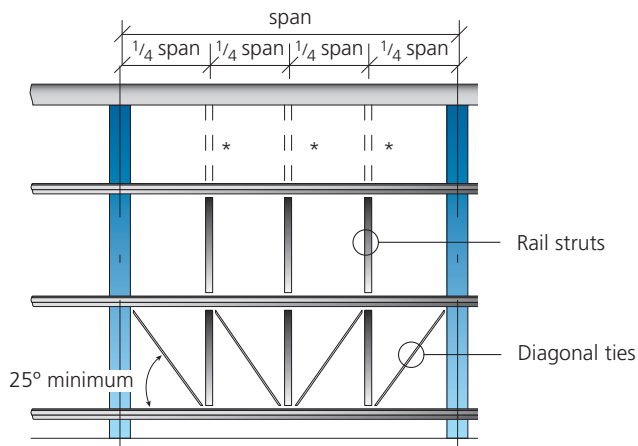

TRIPLE ROW STRUT SYSTEM

DIAGONAL TIES SHOULD BE ANCHORED TO THE CLEAT BOLTS NEAREST THE COLUMN FLANGE

PURLINS, RAILS & EAVES BEAMS

ZED AND CEE SHEETING RAILS

HORIZONTAL WALL CLADDING REQUIREMENTS

Horizontal cladding is often used in conjunction with cold rolled rail systems. Some examples are provided to assist the designer in deciding suitable cladding support. In all cases the eaves beam or structural top member should be checked for horizontal wind loading, in addition to any vertical loading.

Type 1

Eaves Beam designed for wall cladding weight

The number and position of vertical rails will depend on cladding requirements. Horizontal rails should generally be selected as for vertical claddings, but load capacity may require to be reduced when the spacing between vertical rails exceeds 2 metres. (Refer to Steadmans.)

Type 2

Eaves member not designed to carry wall cladding weight

Horizontal rails should be selected as above. The minimum number of sets of diagonal ties should be as given in the table on page 22. Vertical rails should be spaced to suit the cladding but should also satisfy the minimum angle shown for diagonal ties. Load capacity for horizontal rails may require to be reduced when the spacing between vertical rails exceeds 2 metres, as noted above. Support cleats should be checked for their capacity to handle wall cladding weight where this exceeds 13kg/m² or where flat plate cleats are used.

Type 3

Vertical Rail System

Vertical rails should be selected as for a Butted rail system of the same span as the vertical distance between top and bottom supports. Use horizontal struts at the minimum number of locations as recommended for sag members for the same span. The top member may be a structural section or eaves beam depending on the nature of construction. The base of the posts may be fixed to the floor or a structural section can be used. Top and bottom members must be designed for horizontal wind loading as dictated by the construction details.

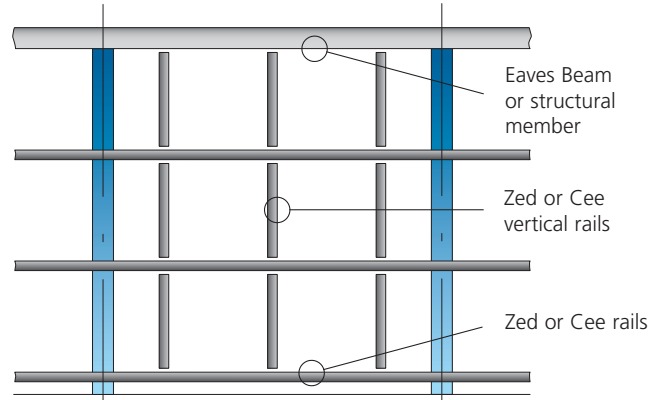

TYPE 1

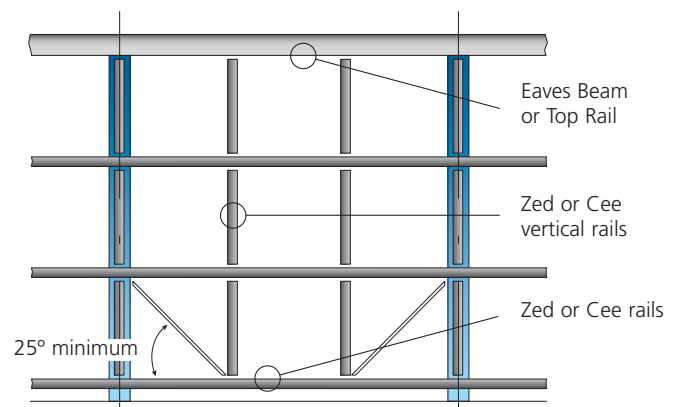

TYPE 2

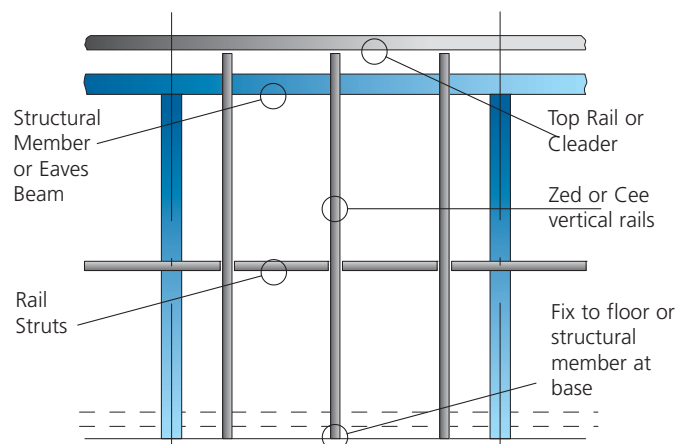

TYPE 3

FIRE RATED BOUNDARY WALLS

Under boundary conditions it is required to provide walls with a fire rating. In these cases the fire rating is provided by the wall cladding and insulation, which are taken to be independent of the rail system in a fire situation. However, rails are required to have slotted end-holings to reduce buckling due to the significant thermal expansion during fire conditions. Connections utilise combustible washers as indicated, to facilitate these thermal movements, whilst providing for normal rail performance during non-fire conditions. (Some approving authorities also require that the eaves beam be fire protected.)

The Steadmans fire rail system has been developed to provide a suitable facility for expansion through slotted holes on the sleeves and cleats. Thus, the system can be used for sleeved and butted rails without limiting the joint positions, provided the slotted cleats and sleeves are adopted, all as indicated here and in the detailing section. The system may be used for spans up to 10m.

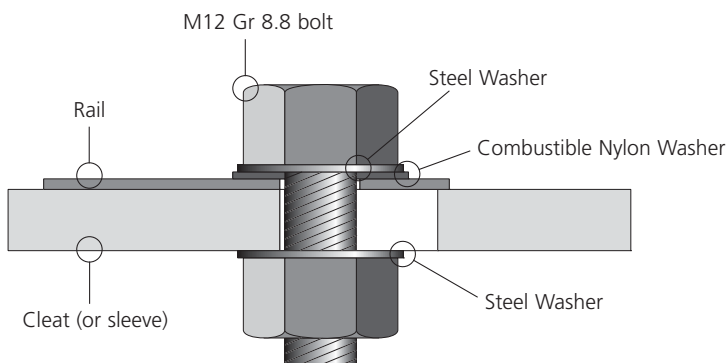
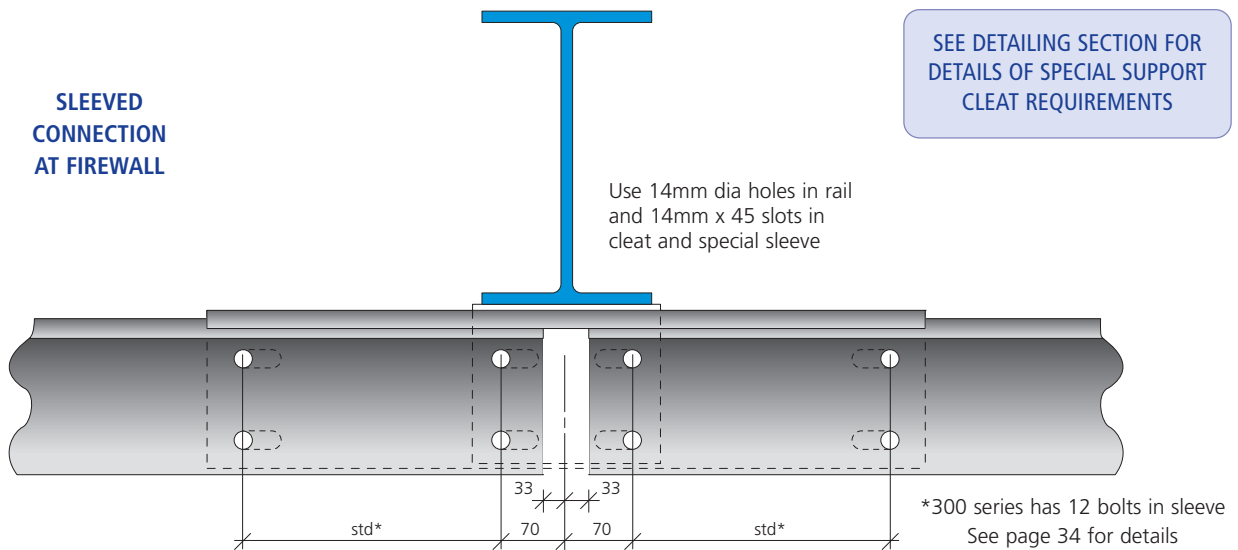
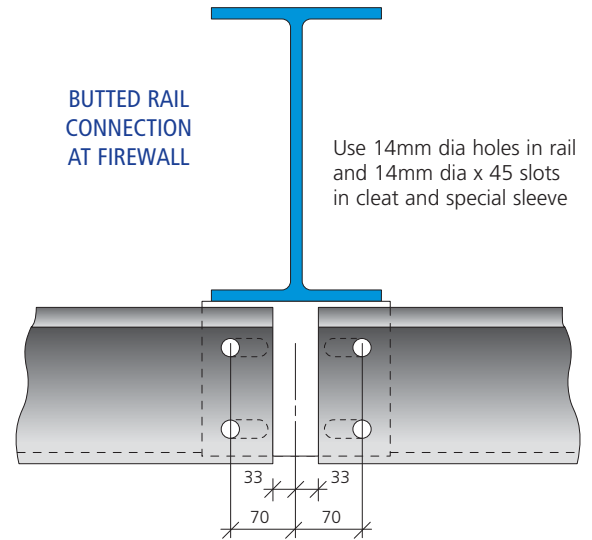

Details are shown here for zed rails but they apply equally to Cee section rails. See page 34 for detailing information.

**ENLARGED BOLT DETAIL
SHOWING COMBUSTIBLE
PLASTIC WASHER**

PURLINS, RAILS & EAVES BEAMS

ADDITIONAL DETAILS

TYPICAL ZED SECTION DETAILS (CEE SECTIONS SIMILAR)

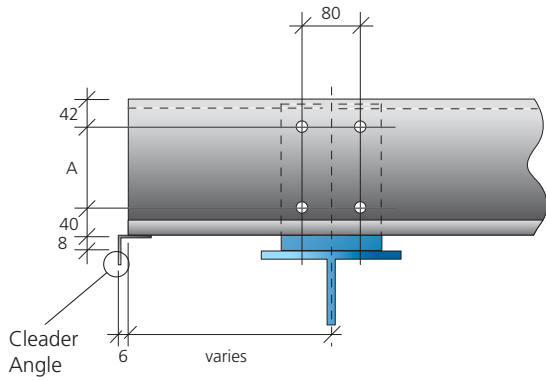

GABLE PURLIN DETAIL

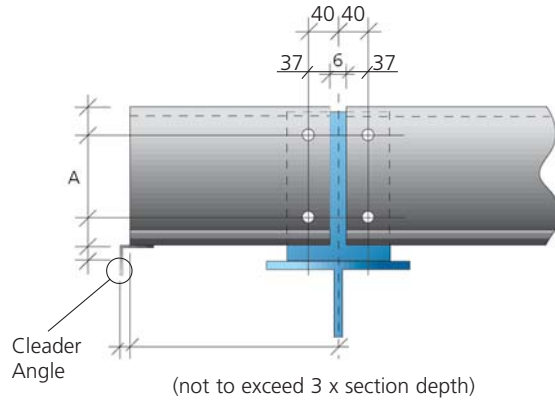

ALTERNATIVE GABLE PURLIN DETAIL
(or can use a sleeve at extendable gable)

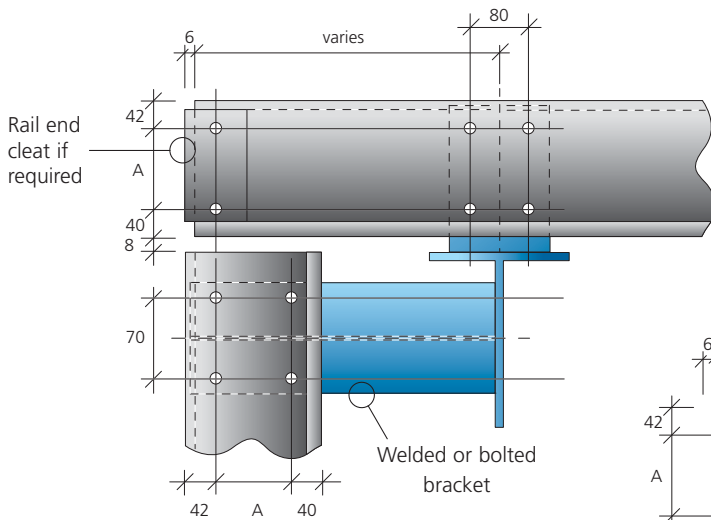

CORNER RAIL CONNECTIONS

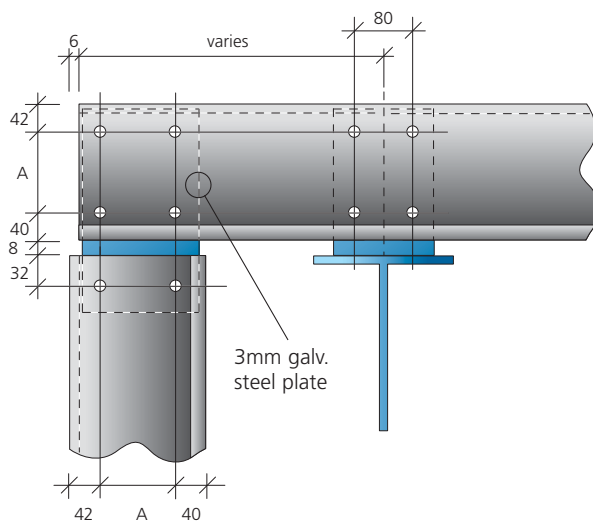

ALTERNATIVE CORNER RAIL CONNECTION

Table 08

Depth	A
140	58
170	88
200	118
240	158
300	218

Dimensions in mm

PARAPET FRAMING

Steadmans produce a variety of zeds and cees which can provide a flexible range of solutions to parapet framing.

Parapet posts may be fabricated from standard Cee sections bolted together to form double-cees at rail positions and at centres not exceeding 1500mm. (Use the thickest section available for the post depth used, to assist with absorbing bolt tension at the connection.)

Use posts of same depth as rails for flush and convenient connections.

Posts may be bolted to columns via 8mm packer plates. Connection should be designed to suit height of parapet but height between pairs of bolts should not be less than 500mm and use backing plates at the flange when bolt tension exceeds the flange capacity.

Alternatively, for higher wind loadings it may be preferred to weld 6mm fin-plates to the column flanges and to bolt the cees sections on either side.

Particular attention should be paid to wall sag systems to remove sag, when gutters are supported from the rails.

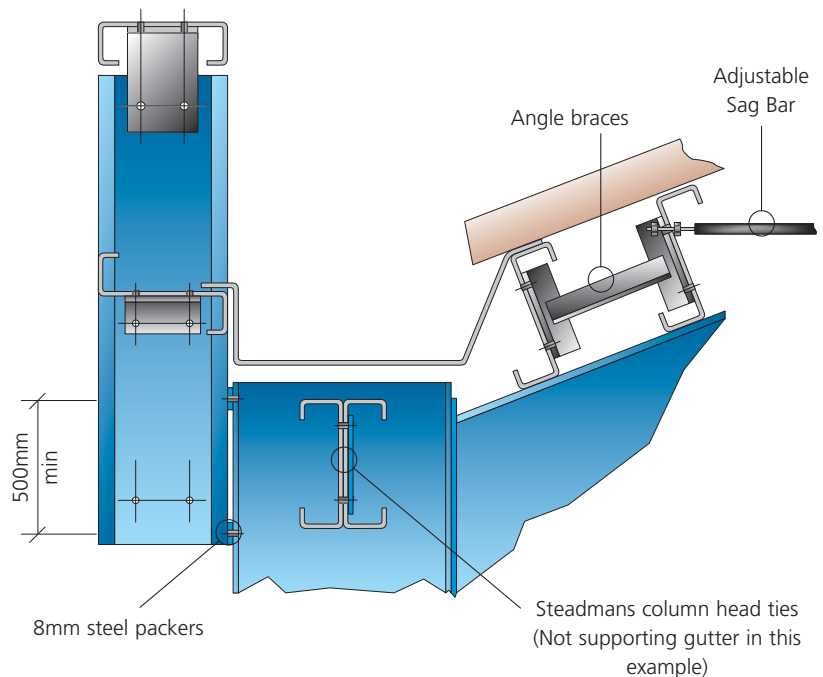

EXAMPLE WITH POST BOLTED TO COLUMN FLANGE

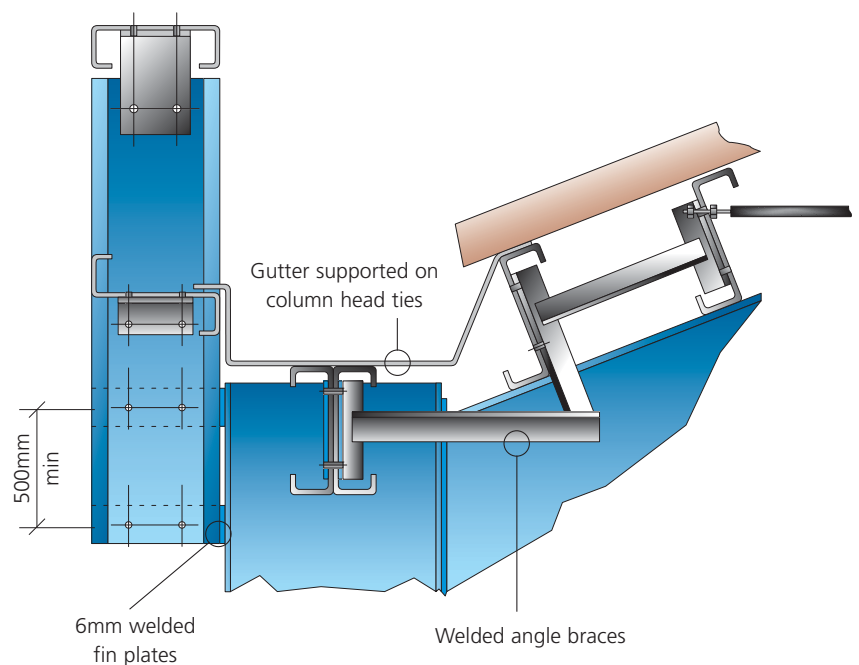

EXAMPLE WITH POST BOLTED TO FIN PLATES AND GUTTER SUPPORTED ON HEAD TIES

PURLINS, RAILS & EAVES BEAMS

ADDITIONAL DETAILS

VALLEY BEAM DETAILS

Cold rolled cees in back-to-back configuration are commonly adopted for support of valley gutters and/or valley column ties. Cees should be bolted together in pairs on the standard gauge lines at ends and at centres not exceeding 1500mm.

Section properties of selected double-Cee beams are provided to assist with design. Design should be carried out to BS 5950-5:1998 or by reference to Steadmans.

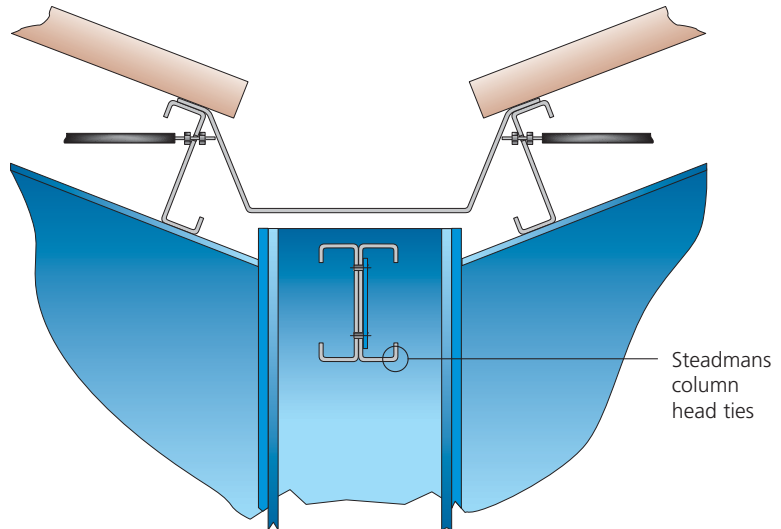

HEAD TIE DETAIL WITH NO GUTTER SUPPORT

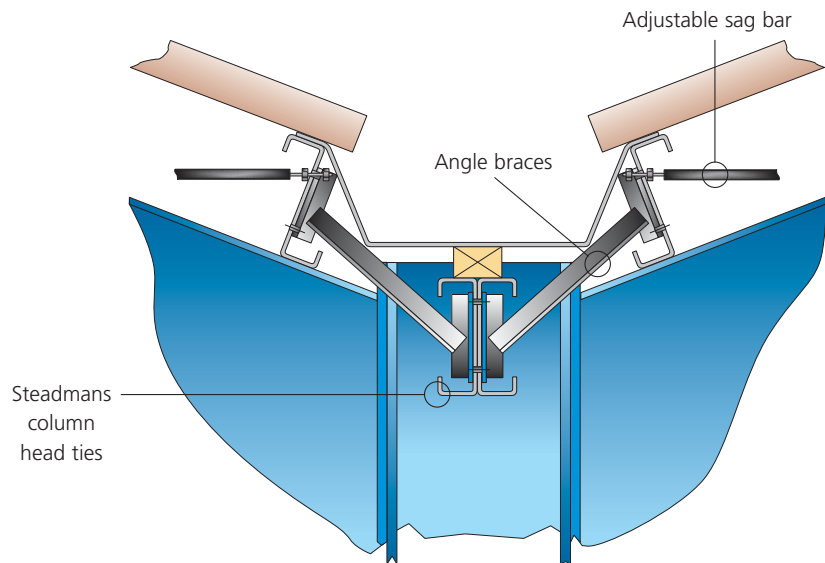

HEAD TIE DETAIL WITH GUTTER SUPPORTED BY HEAD TIES

Table 09: Section properties for selected double-cee sections

Section	Weight (kg/m)	S _{xe} (cm ³)	I _{xx} (cm ⁴)	R _{yy} (mm)	R _{xx} (mm)	Mc (kNm)
2@C170/18	8.94	59.16	508	29.6	66.8	18.86
2@C200/18	10.06	76.58	778	30.8	77.9	24.26
2@C240/20	12.78	114.22	1384	31.8	92.2	35.48
2@C300/25	20.00	224.10	3405	40.1	116.0	69.50
2@C300/30	23.94	268.90	4046	40.0	115.0	88.48

DOOR AND WINDOW FRAMING

Cee Sections are particularly suited for trimming door and window frames.

Counterformed holes are available as an option, though the use of timber packers at windows and door frames are recommended in order to take up tolerances and slight misalignments and in these cases normal or thin-head bolts may be simpler and more economical.

If cold rolled sections are used as framing for overhead doors, then:

1. Check that eaves beam can carry any horizontal wind forces, add eaves braces or a double-Cee head section, as required.
2. Confirm with door supplier that the thin section can carry local forces from the springs and rollers.
3. Use maximum available thickness for section depth utilised.
4. If impact damage is likely then add bollards to protect steelwork and cladding.

TYPICAL DOOR FRAMING DETAILS

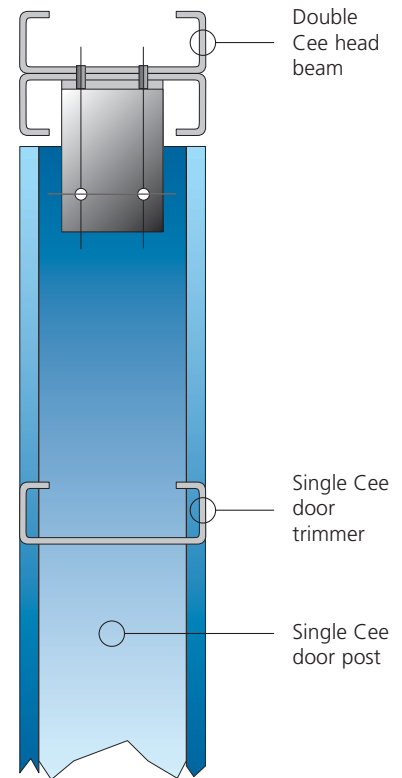
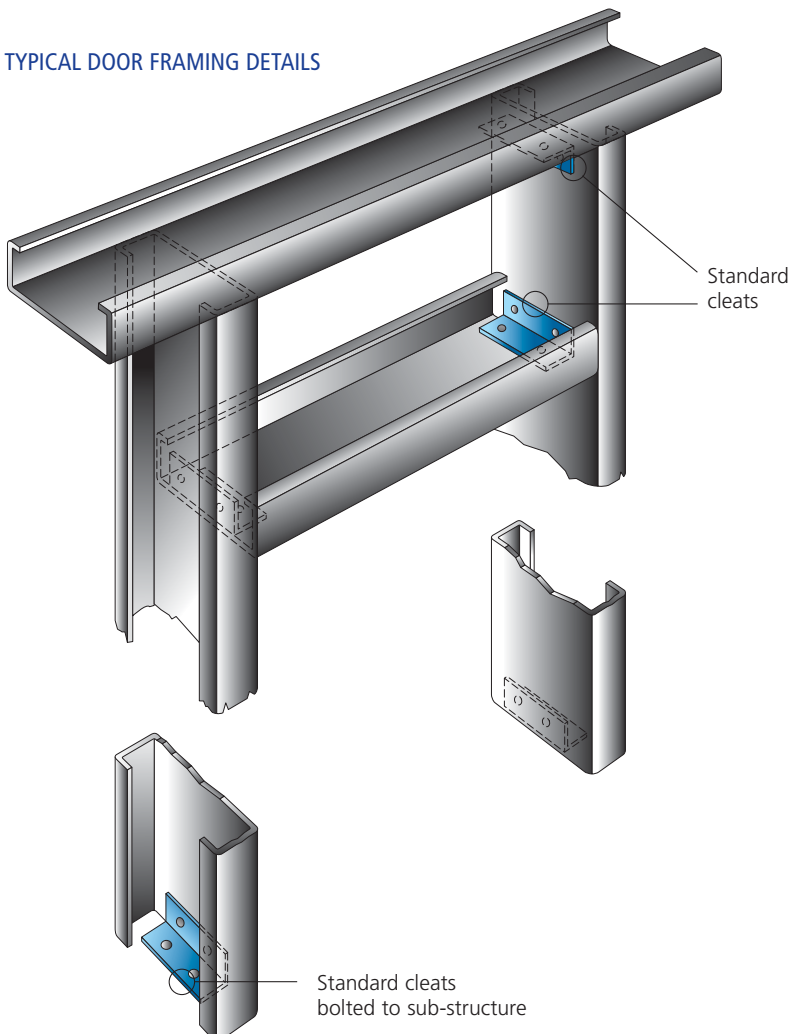

SECTION THROUGH TYPICAL OVERHEAD DOOR

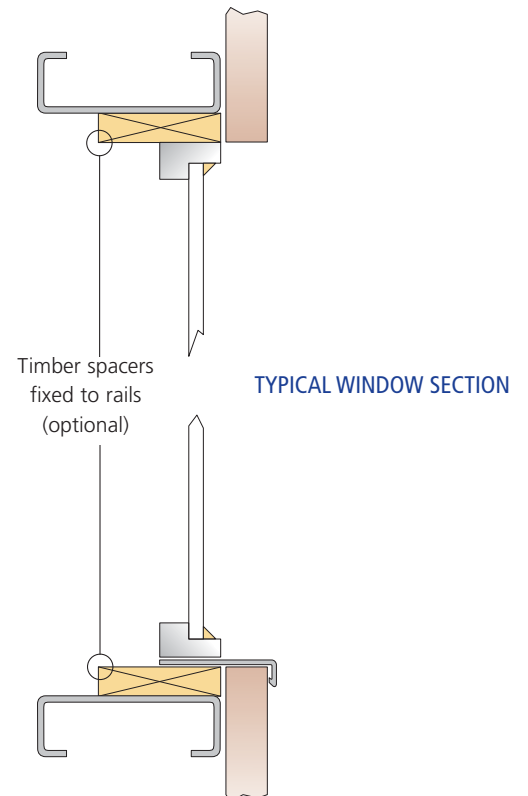

TYPICAL WINDOW SECTION

PURLINS, RAILS & EAVES BEAMS

ADDITIONAL DETAILS

SUSPENDED SERVICES & POINT LOADS

Services are commonly suspended from the purlins, such loads varying in nature and magnitude. This section gives guidance as to accommodation of the point loadings involved.

The table below gives the maximum single point load (unfactored) value for typical light loading applications. For use of this table three conditions must be satisfied;

1. Load centres to be not less than 500mm,
2. Purlin must be selected for a total UDL not less than the sum of the dead load + imposed load + a service load not less than the UDL value which would give the same mid span BM as the point loads on a simple beam of the same span,
3. If roof slope exceeds 12° then reduce allowable load linearly to a value of 50% the tabulated value, at a maximum slope of 25°.

For heavier point loadings a steel framework should be adopted as shown below. Maximum point loads applied to the purlin for this system should be determined in agreement with Steadmans.

Table 10: Maximum value for point loads for loading cases A and B

Thickness	Type A	Type B
1.4 - 1.6	10kg	20kg
1.8 - 2.0	15kg	30kg
2.5 - 3.0	20kg	40kg

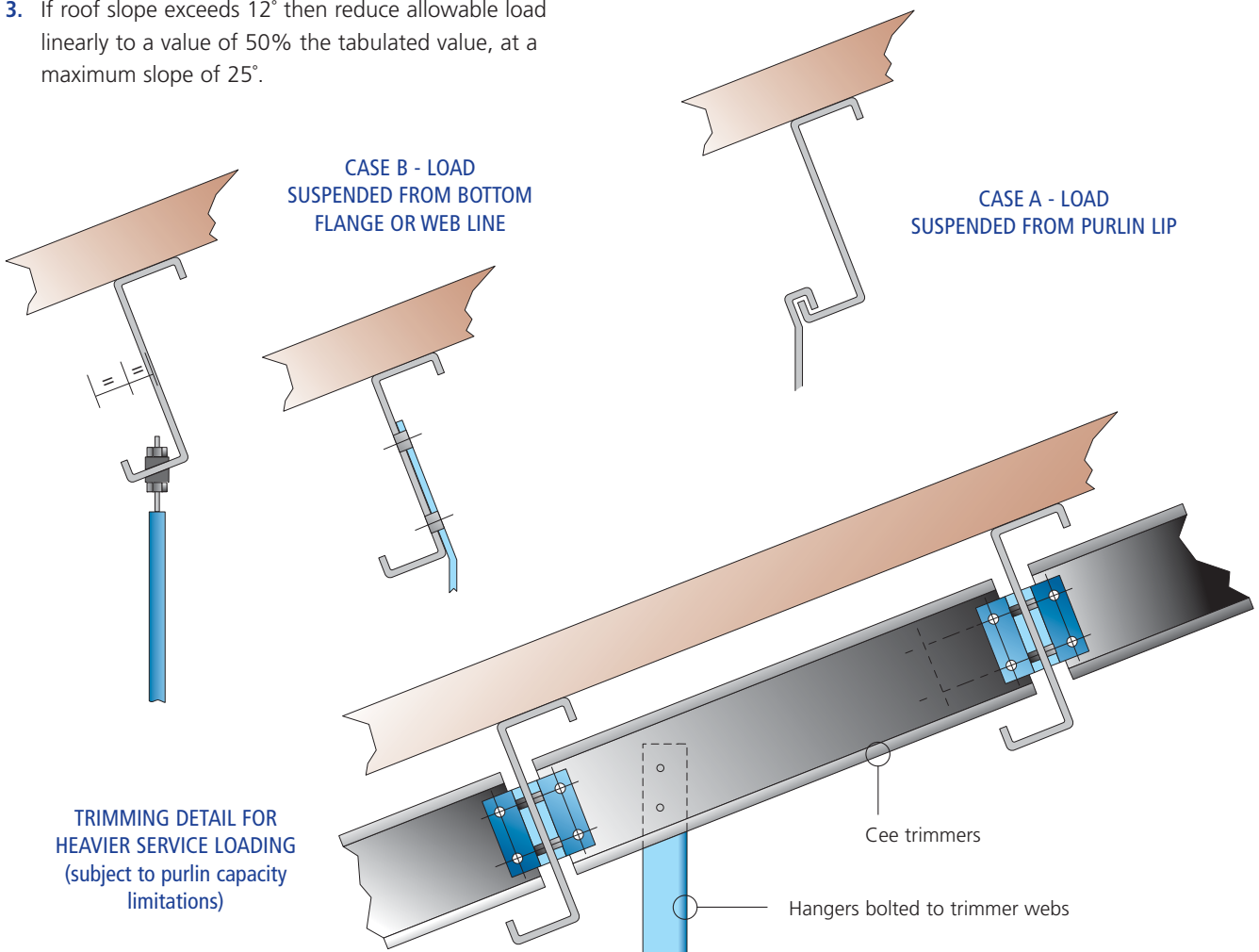

SUSPENDED CEILINGS

Cold rolled sections are increasingly being used as suspended ceiling supports. Support may be provided by either zeds or cees, provided that sections are properly restrained against twisting and buckling. Sections may be used over or under supports depending on individual circumstances.

Typical details are provided for illustration purposes. Steadmans may be contacted for advice and section design for any application or alternatively use the simplified method provided below.

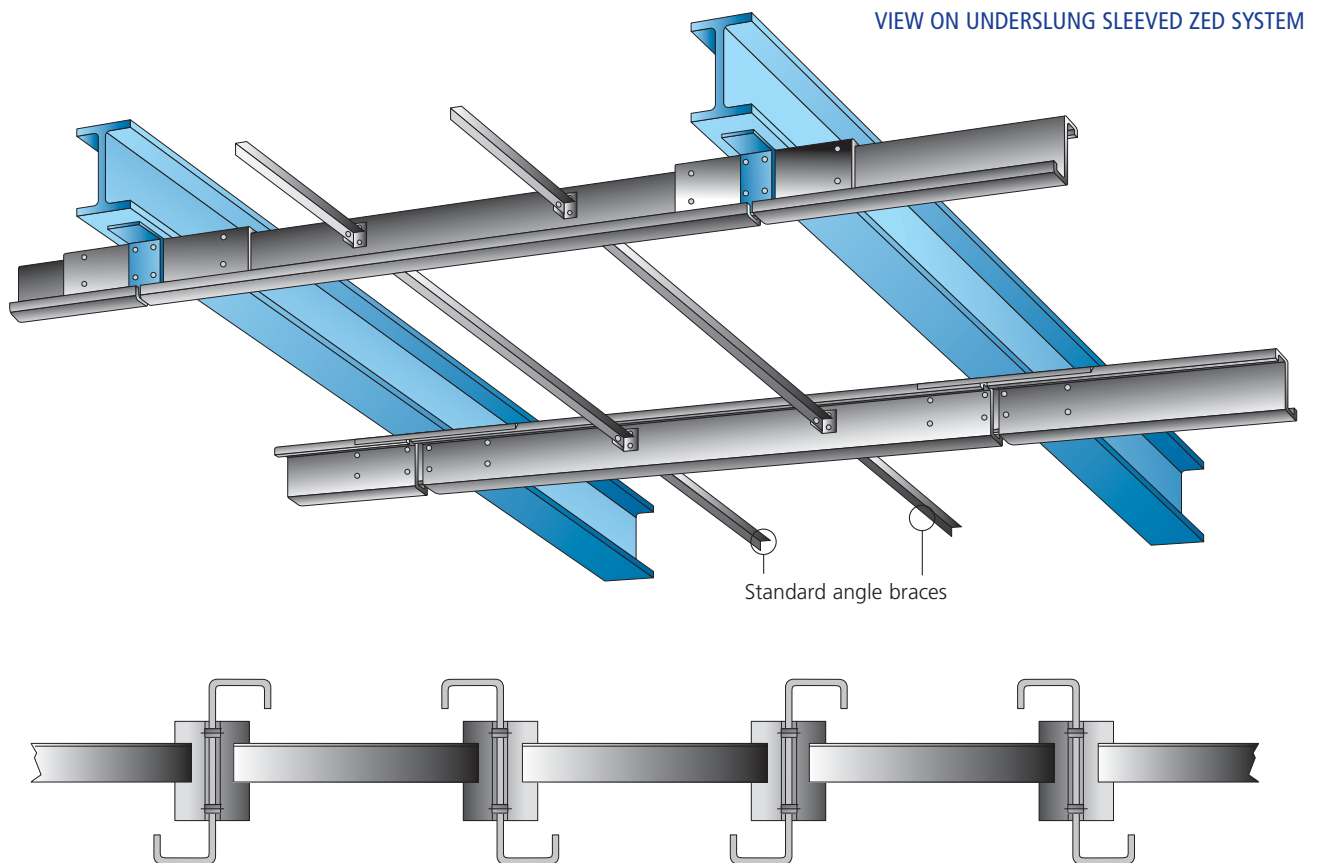

TYPICAL SECTION THROUGH ZEDS SHOWING ALTERNATE DIRECTIONS OF SECTIONS

Notes:

1. Torsional and lateral restraint should be applied at supports (cleats) and at mid-span for spans up to 6.1m and at third spans for spans up to 10m. Such restraints should be tied back to a suitable anchorage to prevent lateral movement of the support grid.
2. Select sections of a suitable stiffness to provide a deflection not exceeding the limits provided by the ceiling supplier (usually span/240 to span/360).
3. Zeds may be single spanning or may be sleeved, if details suit. Cees are generally used as single spanning sections.
4. Whether zeds or cees are used they should be used in opposing pairs, as illustrated, to minimise any twisting effects.
5. Sections may be selected from the load tables in the normal way but the tabulated gravity load capacities should be reduced by 50% to allow for the reduced restraint. (No reduction required for deflection controlled values.)

Alternatively, use the design program with 'non-restraining' cladding.

PURLINS, RAILS & EAVES BEAMS

DETAILING INFORMATION

ZED PURLIN AND RAIL HOLE PUNCHING DETAILS

HEAVY END-BAY SYSTEM

With this system, heavy gauge sections are used in the end bays and at penultimate support sleeves. Care must be taken to properly identify components on site to avoid misplacement. Usually end-bay purlins can be detailed to be different from inner-bay sections but as sleeves look similar at all positions consideration may be given to using heavy gauge sleeve sections at all supports to avoid wrong positioning.

Table 11

Depth	A	B	C
140	58	235	600
170	88	285	700
200	118	335	800
240	158	435	1000
300	218	435	1300

Dimensions in mm

Note: All holes 14mm dia for M12 bolts, minimum grade 8.8 use a washer under all bolt heads and nuts in contact with sections or sleeves.

ZED SECTION SLEEVES

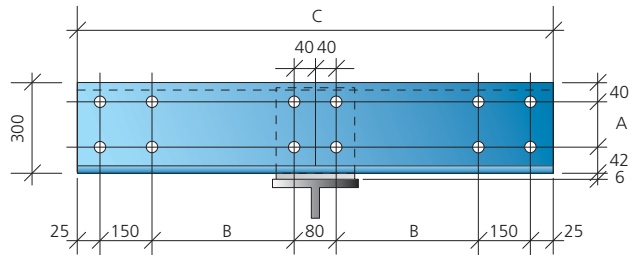

Sleeve for 300 Series

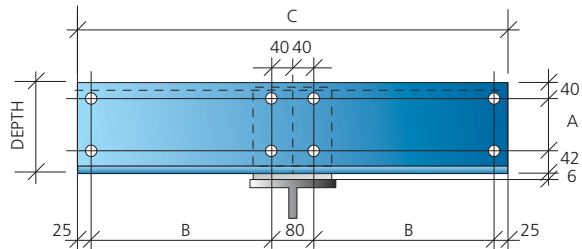

Sleeve for 140, 170, 200 and 240 Series

ZED PURLINS & RAILS

L=section length

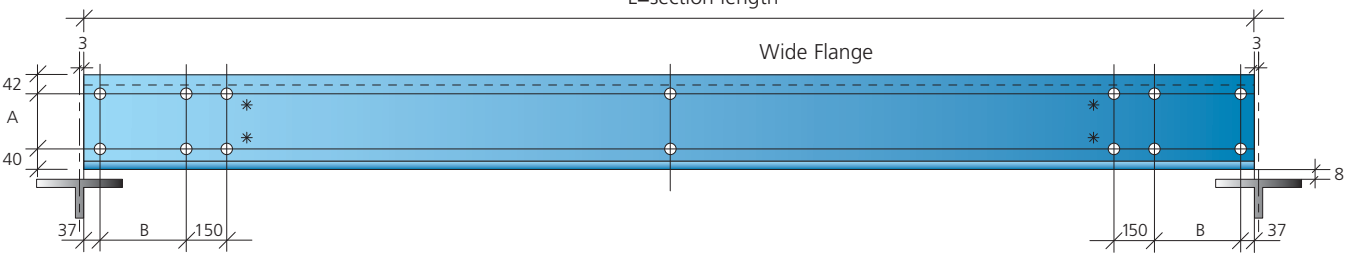

Single spans

Sag bar holing.

Purlins: Use holing at midspan for single row, at 3/8:1/4:3/8 span for double row.

Rails: Use holing at midspan for single row, at 1/3 spans for double row, 1/4 spans for triple row.

* Additional holes required for 300 series sleeves only.

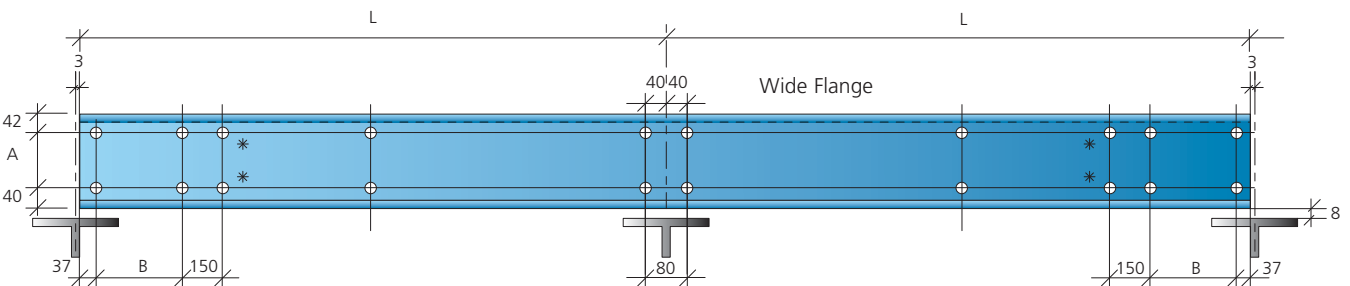

Double spans

CEE RAIL HOLE PUNCHING DETAILS

Table 12

Rail Depth	Sleeve Thickness	A	B	C	D	E	F
140	2.0	58	235	600	146	44.0	150
170	2.5	88	285	700	177	44.5	180.5
200	2.5	118	335	800	207	44.5	210.5
240	3.0	158	435	1000	248	45.0	251
300	3.0	218	435	1300	308	45.0	311

Dimensions in mm

Note: All holes 14mm dia for M12 bolts, minimum grade 8.8. Use a washer under all bolt heads and nuts in contact with sections or sleeves.

CEE SECTION SLEEVES

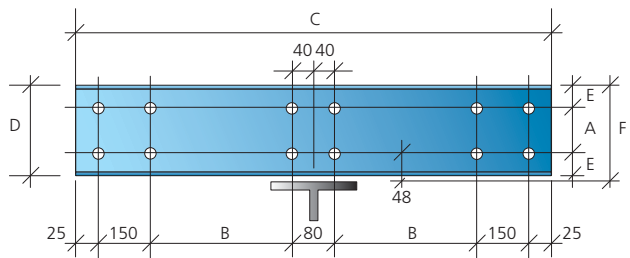

Sleeve for 300 series

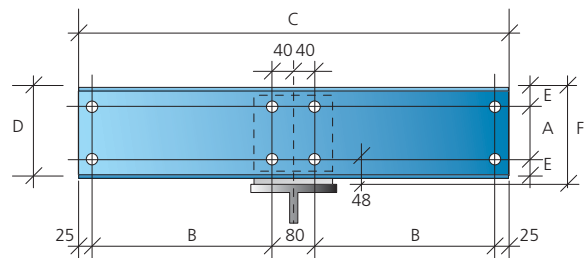

Sleeve for 140, 170, 200 and 240 series

CEE PURLINS & RAILS

L=section length

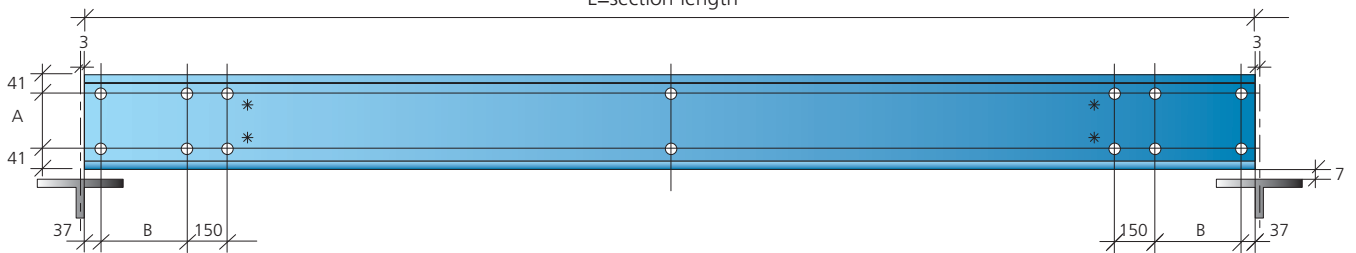

Single spans

Sag bar holing at midspan for single row, at 1/3 spans for double row. 1/4 span for triple row.

* Additional holes required for 300 series sleeves only.

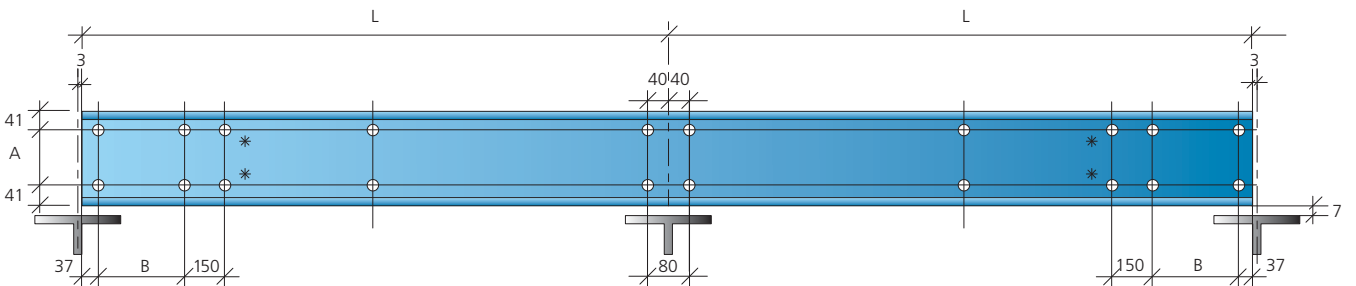

Double spans

PURLINS, RAILS & EAVES BEAMS

DETAILING INFORMATION

FIRE WALL RAIL HOLE PUNCHING DETAILS

ZED SECTIONS

Table 13

Depth	A	B	C
140	58	235	660
170	88	285	760
200	118	335	860
240	158	435	1060
300	218	435	1360

Dimensions in mm

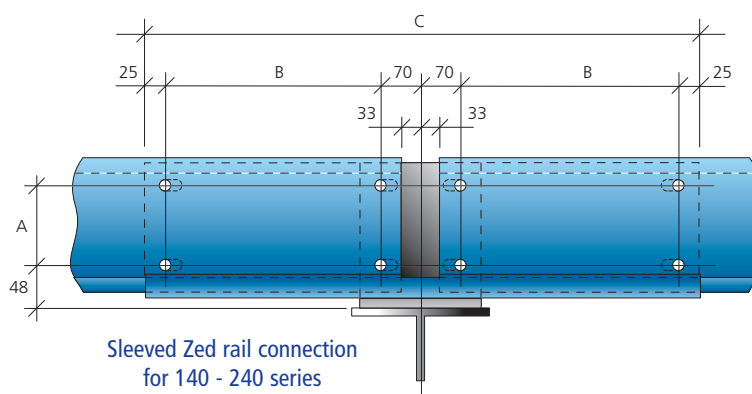
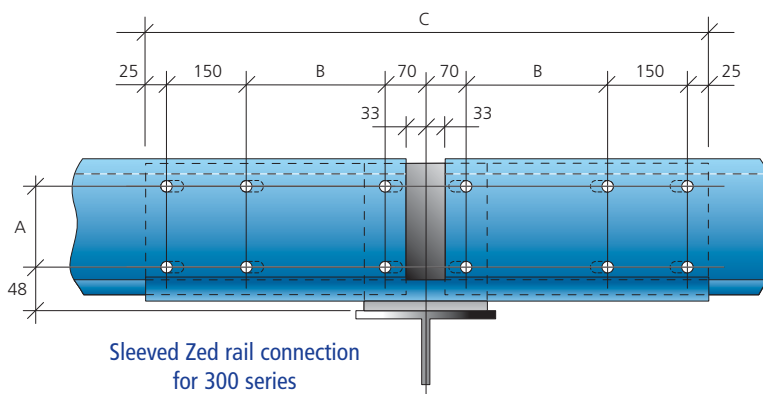
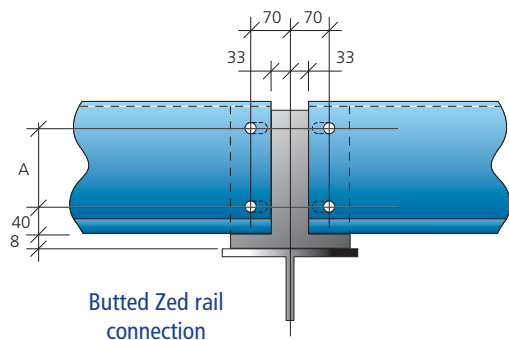

Cee sections

These details should be used in conjunction with information on page 25 and with cleats as detailed on page 35.

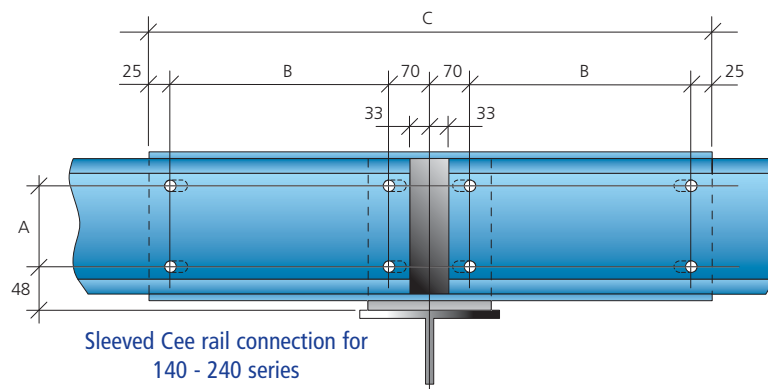
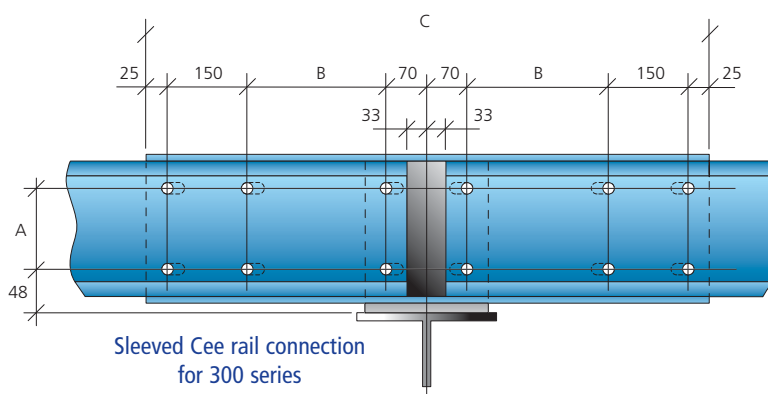
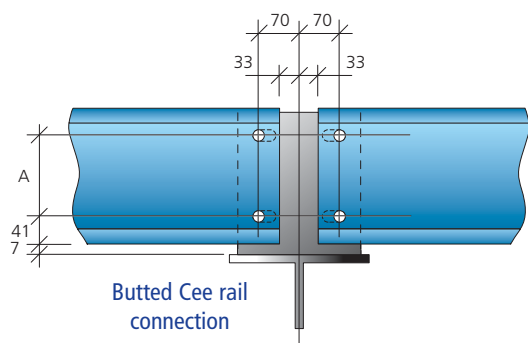

STANDARD CLEATS FOR PURLINS & RAILS

Standard formed cleats - finish: black mild steel

Note for formed cleats:

1. Holes in cleat upstand are 14mm dia for M12 grade 8.8 bolts.
2. Holes in base plate for bolt-on cleats = 18mm dia.
3. For very heavily loaded, steep roofs or heavy wall claddings, Steadmans can on request provide heavy duty cleats reinforced with welded stiffeners.

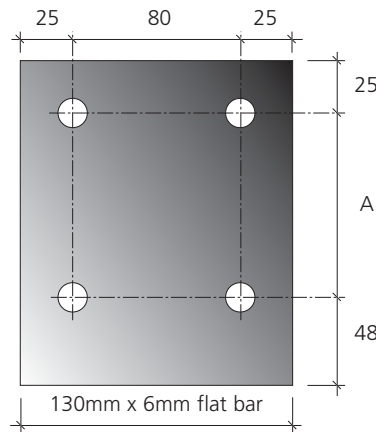

WELDED CLEATS

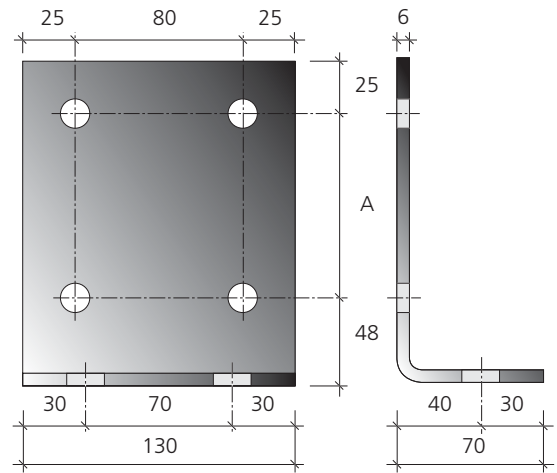

BOLT-ON CLEATS

Fire wall cleats - finish: black mild steel

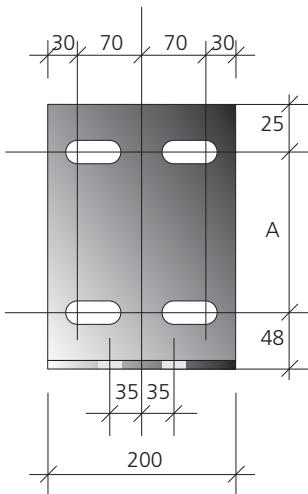

NORMAL FIRE WALL CLEATS

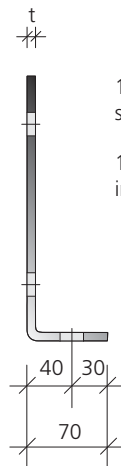

14mm dia x 45mm slots in long leg

18mm dia x holes in short leg

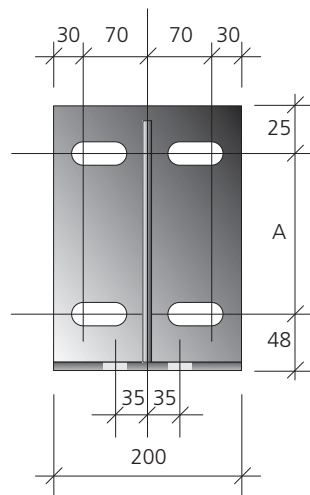

HEAVY DUTY FIRE WALL CLEATS

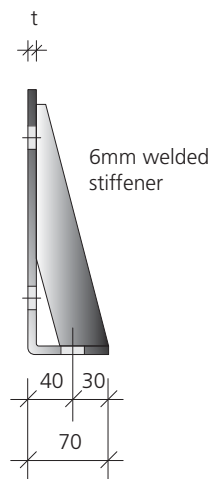

6mm welded stiffener

Note for fire wall cleats:

1. $t = 6\text{mm}$ for 140 to 200 series
 $t = 8\text{mm}$ for 240 and 300 series
2. It is recommended that heavy duty cleats are used for all 300 series connections and for heavy cladding systems.

Table 14

Section Depth	A
140	58
170	88
200	118
240	158
300	218

Dimensions 'A' in (mm)

PURLINS, RAILS & EAVES BEAMS

DETAILING INFORMATION

ANTI-SAG SYSTEM COMPONENTS

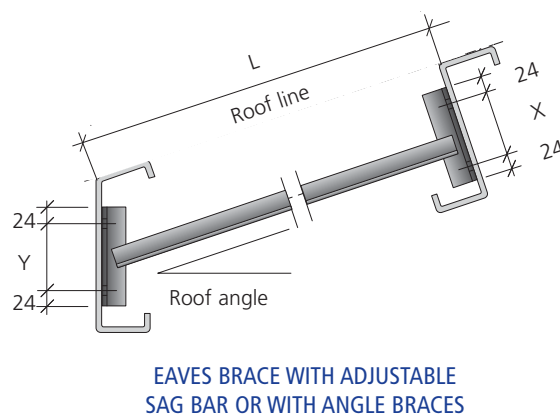
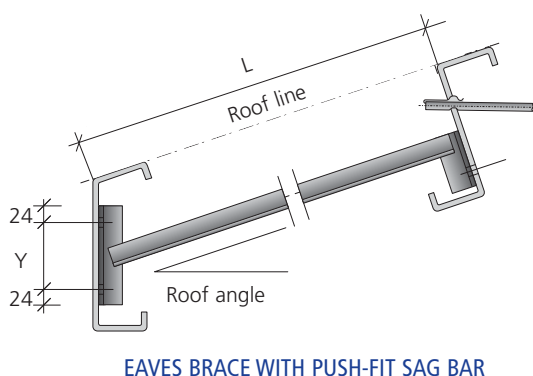
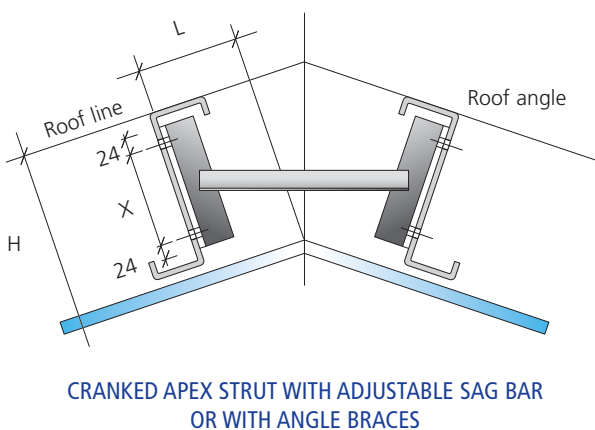
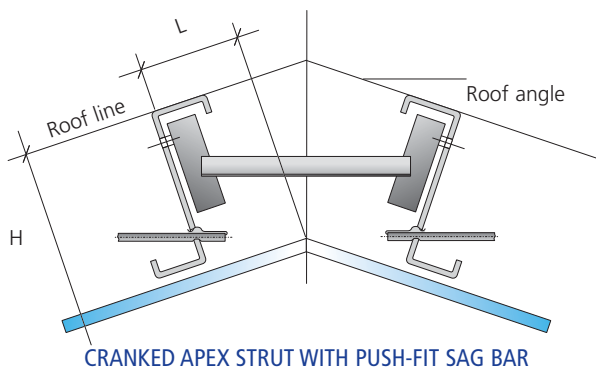
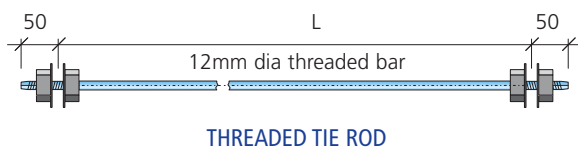
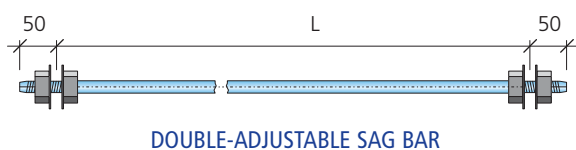
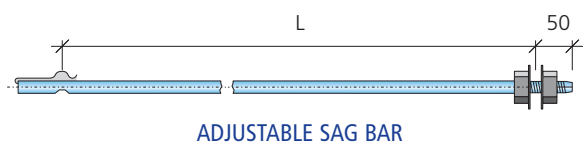

General Notes:

Note that the dimension X refers to the purlin and Y refers to the Eaves Beam. Anchor cleats should be placed at the holes above the rail strut end cleat (and nearest the sheeting) for a single sided diagonal tie position and under the rail strut cleat for a double sided diagonal tie position. The tie top fixing should be bolted to the cleat hole nearest the column.

Note: All holes 14mm dia for M12 bolts, minimum grade 8.8

CLEATS

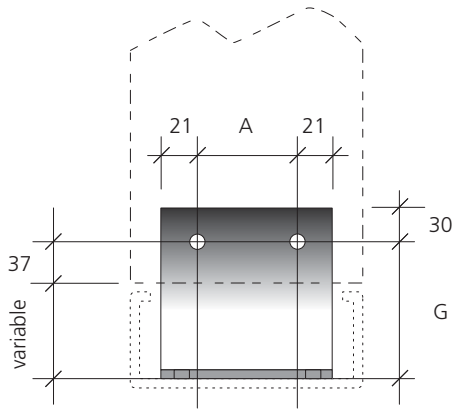

LONG TRIMMER CLEAT

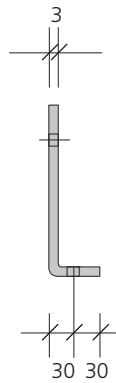
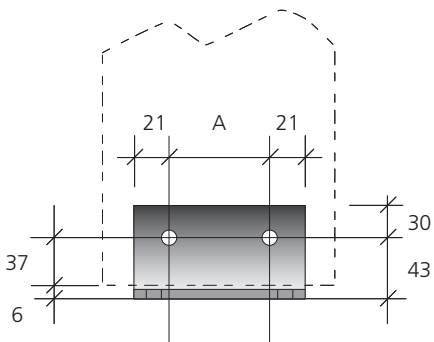

Table 15

Section Depth	A	G
140	58	110
170	88	110
200	118	110
240	158	125
300	218	135

Dimensions in mm

Cleats fabricated from 3mm Galv Z35. Holes 14mm dia for M12 grade 8.8 bolts.



SHORT TRIMMER CLEAT

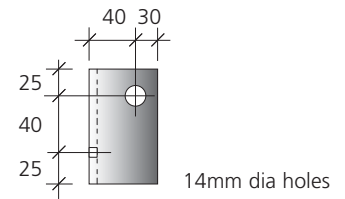
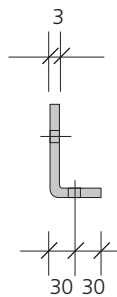

14mm dia holes

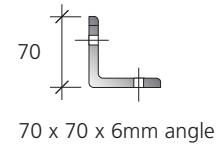

70 x 70 x 6mm angle

STAY CLEAT

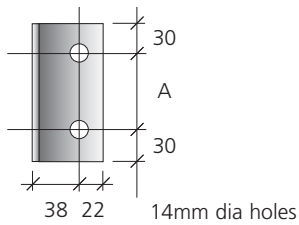

60 x 60 x 2mm zinc plated steel

RAIL END CLEAT

PURLINS, RAILS & EAVES BEAMS

DETAILING INFORMATION

MISCELLANEOUS COMPONENTS

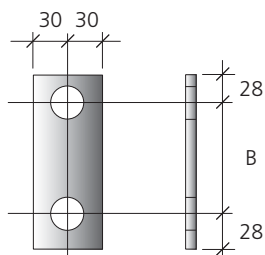

Galv 6mm thick
plate 36mm dia holes

**PACKER PLATE AT
COUNTERFORMED HOLES**

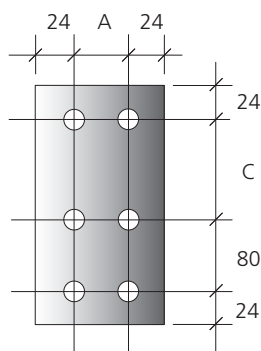

Galv steel 3mm
thick 14mm dia holes

RAIL CORNER JOINING PLATE

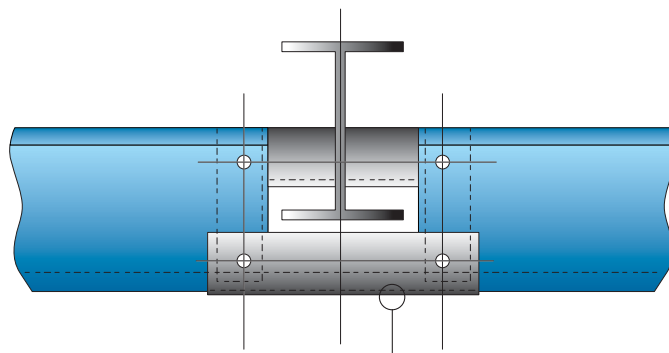

Rail closer from 45 x 70 Galv angle x 2mm thick

RAIL CLOSER DETAIL

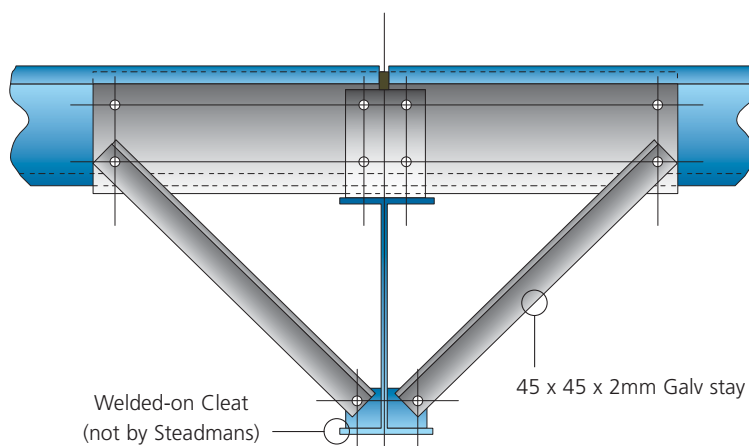

Welded-on Cleat
(not by Steadmans)

45 x 45 x 2mm Galv stay

RAFTER AND COLUMN STAY DETAIL

Table 16

Depth	A
140	58
170	88
200	118
240	158
300	218

Dimensions in mm

Note: All holes
14mm dia for M12
bolts, minimum
grade 8.8
(plated finish)

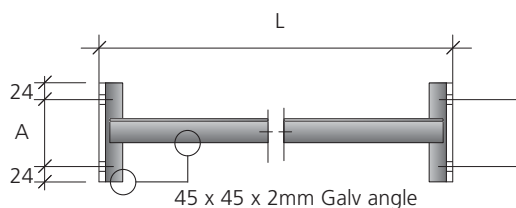

45 x 45 x 2mm Galv angle

STANDARD ANGLE BRACE AND RAIL STRUT

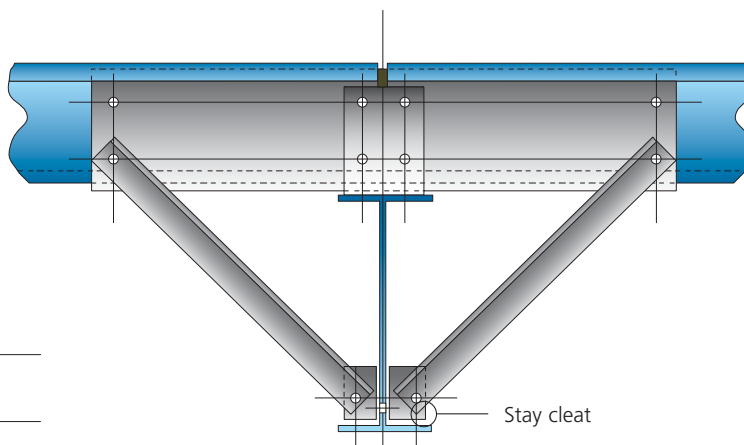

Stay cleat

ALTERNATIVE STAY DETAIL(RAFTER AND COLUMN)

CUSTOM SECTIONS

Steadmans have the ability to brake-press a wide variety of customised sections to suit customers individual requirements. Pressings may be up to 10m long and up to 3.0mm in thickness.

Some typical examples are indicated to illustrate the flexibility of this approach.



SHEET PROFILES TO MATCH OBSOLETE CLADDING



CUSTOM SECTIONS

COMPOSITE VALLEY GUTTER

Bonded Polyisocyanurate
Foam Core: 30mm, 40mm
or 50mm thick.

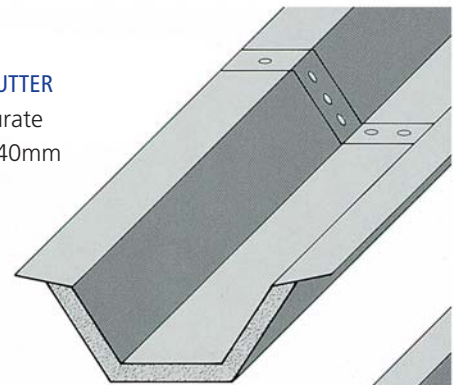

STRUCTURAL GUTTER

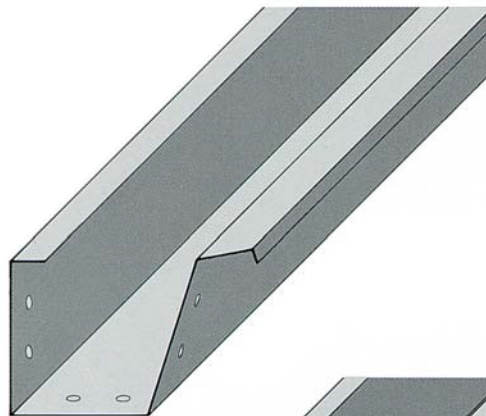

TYPICAL BOUNDARY WALL BOX GUTTER

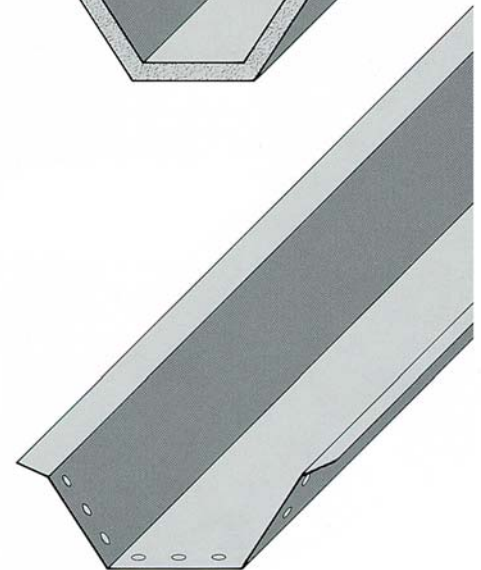
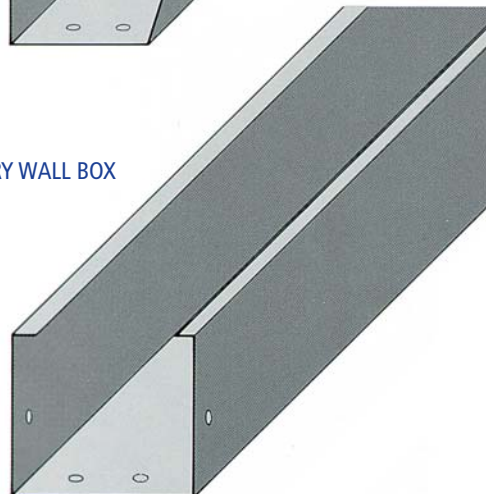

TYPICAL VALLEY GUTTER

Available up to
1250mm in girth.

PURLINS, RAILS & EAVES BEAMS

TECHNICAL SUPPORT

Steadmans offers comprehensive technical support to designers and contractors working with Steadmans products and accessories, including:

- technical brochures and data sheets
- CAD details
- copies of test certificates
- loading calculations
- NBS Specifications
- design and installation guidance
- project showcase and case studies

All the support information above can be downloaded direct or requested from our website.

www.steadmans.co.uk

To contact our Technical Department:

- tel: 01697 478 277
- fax: 01697 478 530
- email: support@steadmans.co.uk

To contact our Sales Department:

- tel: 01697 478 277
- fax: 01697 478 530
- email: info@steadmans.co.uk

TECHNICAL BROCHURES

Our technical brochures contain all the performance, design and sitework information specifiers require to select, incorporate and specify Steadmans products into a project.

All our brochures are available in PDF format for immediate download from our web site. Printed copies are also available upon request.

CAD DETAILS

All the design details contained in our technical brochures are being made available for free in AutoCAD 2004 format for incorporating into project designs.

To access the current range of details, go to the Support section of our web site and select the 'Downloads' link.

There is no need to register to use our details.

TEST CERTIFICATES

Copies of test certificates are available upon request from our Technical Department.

LOADING CALCULATIONS

For loading calculations contact our Technical Department - see details opposite.

NBS SPECIFICATIONS

NBS Plus is a library of technical product information written in NBS format, linked to NBS clauses and clause guidance.



With NBS Plus, specifiers can select products quickly and accurately then drop the product information directly into a specification.

NBS clauses for AS twin skin roof and wall systems and other Steadmans products are now available for NBS subscribers. To access NBS Plus, go to our web site and click on the link on the home page.

DESIGN & INSTALLATION GUIDANCE

Design and installation guidance for the AS35 system, Single Skin system, Twin Skin system, Meta-Slate & Meta-SlatePlus systems are contained in the individual technical brochures and manuals.

These can all be downloaded from the 'Literature' section of the Steadmans web site.

In addition, we also provide installation instruction sheets for various applications. Links for these are located on the 'Downloads' page in the Support section of our web site.

REFERENCES

- Approved Documents
 - A Structure
 - B Fire safety
 - C Site preparation and resistance to contaminants and moisture.
 - L2A Conservation of fuel and power in new buildings other than dwellings.
 - L2B Conservation of fuel and power in existing buildings other than dwellings.
- The Scottish Building Standards: Technical Handbook.
 - Non-domestic.
- BS 476 Fire tests on building material and structures.
 - BS 476-3:2004 Classification and method of test for external fire exposure to roofs.
 - BS 476-7:1997 Method of test to determine the classification of the surface spread of flame of products.
 - BS 476-22:1987 Methods for determination of the fire resistance of non-loadbearing elements of construction.
- BS 5250:2002 Code of practice for control of condensation in buildings.
- BS 5950-5:1998 Structural use of steelwork in building. Code of practice for design of cold formed thin gauge sections
- BS EN 1090-2:2008 Execution of steel structures and aluminium structures. Technical requirements for the execution of steel structures.
- BS EN 1993-1-3:2006 Eurocode 3. Design of steel structures. General rules. Supplementary rules for cold-formed members and sheeting
- BS 8206 Lighting for buildings.
 - BS 8206-2:2008 Code of practice for daylighting.
- BS EN 10143:2006 Continuously hot-dip coated steel sheet and strip. Tolerances on dimensions and shape.
- BS EN 10346:2009 Continuously hot-dip coated steel flat products. Technical delivery conditions.
- BS EN 12056 Gravity drainage systems inside buildings.
 - BS EN 12056-3:2000 Roof drainage, layout and calculation.
- BS EN ISO 10211:2007 Thermal bridges in building construction. Heat flows and surface temperatures. Detailed calculations.
- BS EN ISO 13788:2002 Hygrothermal performance of building components and building elements. Internal surface temperature to avoid critical surface humidity and interstitial condensation. Calculation methods.
- MRCMA Technical paper 14. Guidance for the design of metal roofing and cladding to comply with Approved Document L2: 2001
- TM 37: Design for improved solar shading. 2006

PURLINS, RAILS & EAVES BEAMS TECHNICAL SUPPORT

STEADMAN'S WEBSITE

The Steadman's website is a comprehensive, easy to navigate database of information on Steadman's and our complete range of products and services.



The information is divided into seven information sections:

- About Us
- Product Range
- Support
- Case Studies
- News
- Literature
- Links

We strive to ensure that using the website is as rewarding as possible and always welcome any feedback you have regarding the content and usability of our website.

Product range

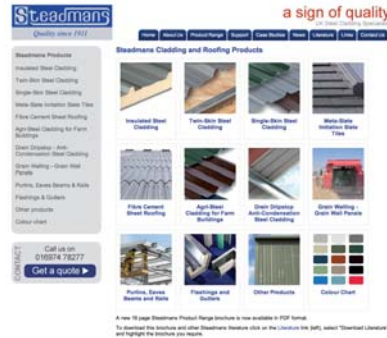

All the information contained in our technical brochures is included on the website along with download pdfs of individual brochure sections of some products covering design guidance, technical details and performance data. This section also includes additional products which do not have printed or download brochures.

Support



The Support section includes information on Fire Performance and Warranties, a list of Frequently Asked Questions, links to other relevant Organisations/Trade Associations/ Building Regulations and to our NBS Plus Specifications. You can also request information and download literature and installation instructions for our sheets and other products.

Case Studies



The Case Studies section contains information and photographs of recent projects.

News



All the latest Steadman's news.

Literature



This is a quick link to a page where you can request printed copies of our brochures or download electronic copies in PDF format.

Steadmans are always happy to provide advice on the specification of our single skin system and all of our other products for refurbishment and new build projects.



Whatever the nature, size and location of your project, we can provide the expertise and delivery schedules essential to its success.



With more than £3 million of stock available for immediate delivery, Steadmans have built up an enviable reputation for providing quality products, promptly and at competitive prices - a service which has attracted many loyal customers.



Our dedicated fleet of delivery vehicles with self off-load facilities also means that the personal care taken to produce our high quality products is maintained throughout the stages of manufacture to the final delivery to our customer.



A. Steadman & Son

England & Wales

Warnell, Welton
Carlisle
Cumbria
CA5 7HH

Tel: 01697 478 277

Fax: 01697 478 530

Northern Ireland & Ireland

Unit 5, Scarva Road Ind. Est.
Banbridge, Co. Down
Northern Ireland
BT32 3QD

Tel: 02840 660 516

Fax: 02840 660 517

Scotland

New Edinburgh Road
View Park
Uddingston
G71 6LL

Tel: 01506 437 753

Fax: 01506 440 716

Mill of Crichtie
Fyvie, Turriff
Aberdeenshire
AB53 8QL

Tel: 01651 891 668

Fax: 01651 891 698

E-mail: info@steadmans.co.uk

Online: www.steadmans.co.uk

ENVIRONMENTAL CREDENTIALS

We recognise the need to manage the impact which our business and processes have on the environment. We believe we have a responsibility to contribute to the well-being of the communities we live in. We are committed to providing a clean, safe environment.

Developing sustainable construction methods presents a challenge to the whole construction industry. Our main raw material, steel, is eminently recyclable: 85 - 90% of steel from demolition goes for re-use and 40% of steel used in new construction has been recycled.

By using modern machinery and upgrading our facilities we are continually reducing the impact of our products on the environment, and improving their contribution to the long-term performance of buildings.

www.steadmans.co.uk

n55Plus

riba
product
selector

